

GOODWE



User Manual

All-In-One Outdoor Energy Storage System

Lynx C Series

60kWh (Outdoor)

Copyright © GoodWe Technologies Co.,Ltd. 2023. All rights reserved.

No part of this manual can be reproduced or transmitted to the public platform in any form or by any means without the prior written authorization of GoodWe Technologies Co.,Ltd.

Trademarks

GOODWE and other GoodWe trademarks are trademarks of GoodWe Technologies Co.,Ltd. All other trademarks or registered trademarks mentioned in this manual are owned by the company.

NOTICE

The information in this user manual is subject to change due to product updates or other reasons. This guide cannot replace the product labels or the safety precautions in the user manual unless otherwise specified. All descriptions in the manual are for guidance only.

CONTENT

1	About This Manual	1
1.1	Applicable Model	1
1.2	Target Audience	1
1.3	Symbol Definition	2
2	Safety Precaution	3
2.1	General Safety	3
2.2	System Safety	3
2.3	Battery Safety	5
2.4	Emergency Measures	5
2.5	Personnel Requirements	5
2.6	EU Declaration of Conformity	6
3	Product Introduction	7
3.1	Product Overview	7
3.2	Application Scenarios	10
3.3	Features	10
3.4	Appearance	12
3.4.1	Parts	12
3.4.2	Indicator Description	17
3.4.3	Dimension	17
3.4.4	Nameplate	18
4	Check and Storage	19
4.1	Check Before Receiving	19
4.2	Deliverables	19
4.3	Storage	20
5	Installation	21
5.1	Installation Requirements	21
5.2	Equipment Installation	24
5.2.1	Handling Equipment	24
6	Electrical Connection	30
6.1	Safety Precaution	30
6.2	Connecting the PE cable	32
6.3	Connecting the battery cable	33
6.4	Connecting the power cable for air conditioning	35
6.5	Connect the inverter to the power control unit	36
6.6	Multiple batteries wiring	38
6.6.1	Making Power Cable	38
6.6.2	Making Communication Cable	39
6.6.3	Terminal Resistor Connection	40

7	Equipment Commissioning	41
7.1	Check Before Power ON.....	41
7.2	Open fire fighting device.....	41
7.3	Power On.....	42
8	System Commissioning	44
8.1	Indicators and Buttons.....	44
8.2	Setting Battery System Parameters.....	44
8.3	Closing the cabinet door.....	46
8.4	Pedestal installation.....	47
8.5	Air conditioning drainage pipe installation.....	47
9	System maintenance	48
9.1	Power off the energy storage system.....	48
9.2	Power off the equipment.....	48
9.3	Removing the energy storage system.....	49
9.4	Disposing of the equipment.....	50
9.5	Troubleshooting.....	50
9.6	Routine Maintenance.....	52
10	Technical Parameters	53

1 About This Manual

This manual describes the product information, installation, electrical connection, commissioning, troubleshooting, and maintenance. Read through this manual before installing and operating the product. All the installers and users have to be familiar with the product features, functions, and safety precautions. This manual is subject to update without notice. For more product details and latest documents, visit <https://en.goodwe.com>.

1.1 Applicable Model

This manual applies to the listed energy-storage system below:



Model	Usable Energy
GW60KWH-4H-A-10	60kWh
GW60KWH-3H-A-10	
GW60KWH-2H4-A-10	
GW60KWH-2H-A-10	
GW60KWH-D-10	

1.2 Target Audience

This manual applies to trained and knowledgeable technical professionals only. The technical personnel has to be familiar with the product, local standards, and electric systems.

1.3 Symbol Definition

Different levels of warning messages in this manual are defined as follows:

 DANGER
Indicates a high-level hazard that, if not avoided, will result in death or serious injury.
 WARNING
Indicates a medium-level hazard that, if not avoided, could result in death or serious injury.
 CAUTION
Indicates a low-level hazard that, if not avoided, could result in minor or moderate injury.
NOTICE
Highlights key information and supplements other text. It may include skills and methods to solve product-related problems.

2 Safety Precaution

Please strictly follow these safety instructions in the user manual during the operation.

NOTICE

The inverters are designed and tested to strictly comply with related safety rules. Read and follow all the safety instructions and cautions before any operations. Improper operation might cause personal injury or property damage as the inverters are electrical equipment.

2.1 General Safety

NOTICE

- The information in this user manual is subject to change due to product updates. This guide cannot replace the product labels or the safety precautions in the user manual unless otherwise specified. All descriptions in the manual are for guidance only.
- Before installations, read through the user manual to learn about the product and the precautions.
- All operations should be performed by trained and knowledgeable technicians who are familiar with local standards and safety regulations.
- Use insulating tools and wear personal protective equipment when operating the equipment to ensure personal safety. Wear anti-static gloves, cloths, and wrist strips when touching electronic devices to protect the equipment from damage.
- Strictly follow the installation, operation, and configuration instructions in this guide and user manual. The manufacturer shall not be liable for equipment damage or personal injury if you do not follow the instructions. For more warranty details, please visit <https://en.goodwe.com/warranty>

2.2 System Safety

DANGER









- Strictly follow local laws, regulations, and industry standards during installation and operations.
- Strictly follow the safety labels on the equipment and safety precautions outlined in the user manual of the system or inverter.
- Use appropriate tools and take protective measures when installing and maintaining the heavy energy storage system. Improper operations can result in personal injuries or damage to the system.
- To prevent damages during transportation, ensure that transportation personnel are professionally trained. Record the steps taken during transportation and maintain equipment balance to avoid dropping.
- Install the equipment on a non-combustible surface such as a concrete floor that is horizontal, flat, dry, and sturdy enough to bear mechanical load.
- Lethal high voltage exists. Avoid touching the equipment to prevent electric shock incidents.
- Ensure that the equipment is not damaged and the system is not faulty before any operations. Otherwise, fire or electric shock may occur.

⚠ DANGER

- Disconnect all switches or breakers before installations, cable connections, or maintenance.
- Ensure reliable grounding of the system before any operations. Otherwise an electric shock may occur.
- Do not open the doors and touch any live components or terminals when the equipment is working. Otherwise an electric shock may occur.
- Do not place the equipment in a high temperature environment. Keep it away from heat source and direct sunlight, as a fire may occur when the ambient temperature exceeds 60°C.
- Do not touch running equipment as its temperature may exceed 60°C and result burning harm. Do not install equipment within reach of non-professionals.
- Do not disassemble, modify, or replace any part of the equipment without official authorization from the manufacturer. Warranty does not cover damages caused by unauthorized actions.

⚠ DANGER

- All labels and warning marks should be visible after the installation. Do not cover, scrawl, or damage any label on the equipment.
- Warning labels on the equipment are as follows:

	HIGH VOLTAGE HAZARD High voltage exists when the system is running. Disconnect all incoming power and turn off the system before working on it.		Potential risks exist. Wear proper Personnel Protective Equipment before any operations.
	Read through the user manual before any operations.		Grounding point.
	Beware of fire		Do not dispose of the equipment as household waste. Discard it in compliance with local laws and regulations, or send it back to the manufacturer.
	CE Mark		RCM Mark
	TUV Mark	-	-

2.3 Battery Safety



WARNING

- High voltage exists. Power off the equipment before any operations to avoid electric shock.
- Do not disassemble, modify, or replace any part of the battery or the power control unit without official authorization from the manufacturer. Otherwise, it may cause electrical shock or damages to the equipment for which the manufacturer shall not be held responsible.
- Avoid reverse polarity connection to prevent battery short circuiting. A short circuit in the battery may result in electrolyte leakage, smoke, release of flammable gases, thermal runaway, fire, or explosion.
- Do not hit, pull, drag, or squeeze the battery as this may result in damage or fire.
- Charge the battery promptly after discharging to prevent over-discharging and potential damage.
- Do not use the battery module or power control unit if it is defective, broken, or damaged.
- Damaged battery modules may leak electrolyte.
- Contact after-sales service for replacement if necessary.
- Contact after-sale service immediately if the battery is not able to be started. Otherwise, the battery might be damaged permanently.

2.4 Emergency Measures



WARNING

Damaged battery modules may cause electrolyte leakage. If the battery module leaks electrolyte, avoid contact with the leaking liquid or gas.

Anyone contact the leakage accidentally has to do as the following:

- Inhalation: Evacuate from the contaminated area, and seek immediate medical assistance.
- Eye contact: Rinse your eyes for at least 15 minutes with clean water and seek immediate medical assistance.
- Skin contact: Thoroughly wash the touch area with soap and clean water, and seek immediate medical assistance.
- Ingestion: Induce vomiting, and seek immediate medical assistance.

2.5 Personnel Requirements

NOTICE

- Personnel who install or maintain the equipment must be strictly trained, learn about safety precautions and correct operations.
- Only qualified professionals or trained personnel are allowed to install, operate, maintain, and replace the equipment or parts.

2.6 EU Declaration of Conformity

GoodWe Technologies Co., Ltd. hereby declares that the inverter without wireless communication modules sold in the European market meets the requirements of the following directives:

- Electromagnetic compatibility Directive 2014/30/EU (EMC)
- Electrical Apparatus Low Voltage Directive 2014/35/EU (LVD)
- Restrictions of Hazardous Substances Directive 2011/65/EU and (EU) 2015/863 (RoHS)
- Battery Directive 2006/66/EC and Amending Directive 2013/56/EU
- Waste Electrical and Electronic Equipment 2012/19/EU
- Registration, Evaluation, Authorization and Restriction of Chemicals (EC) No 1907/2006 (REACH)

You can download the EU Declaration of Conformity on <https://en.goodwe.com>.

3 Product Introduction

3.1 Product Overview

Product Overview

The energy storage system consists of an energy storage inverter (to be purchased separately) and an energy storage battery system. The energy storage battery system includes batteries, high-voltage boxes, fire protection systems, and Air conditioning. Multiple energy storage battery systems can be clustered together to achieve capacity expansion.

Model

This manual applies to the listed energy storage system below:

- GW60KWH-4H-A-10
- GW60KWH-3H-A-10
- GW60KWH-2H4-A-10
- GW60KWH-2H-A-10
- GW60KWH-D-10

GW60KWH-4H-A-10



No.	Referring to	Description
1	Brand Code	GW: GoodWe
2	Usable energy code	60KWH: the energy storage cabinet can store 60KWH of electricity.
3	Full Charge Time Code	4H: 4 3H: 3 2H4: 2.4 2H: 2
4	System Features Code	A: Include Inverter D: Battery cabinet only
5	Version Code	10: the energy storage system version is 1.0.

circuit diagram

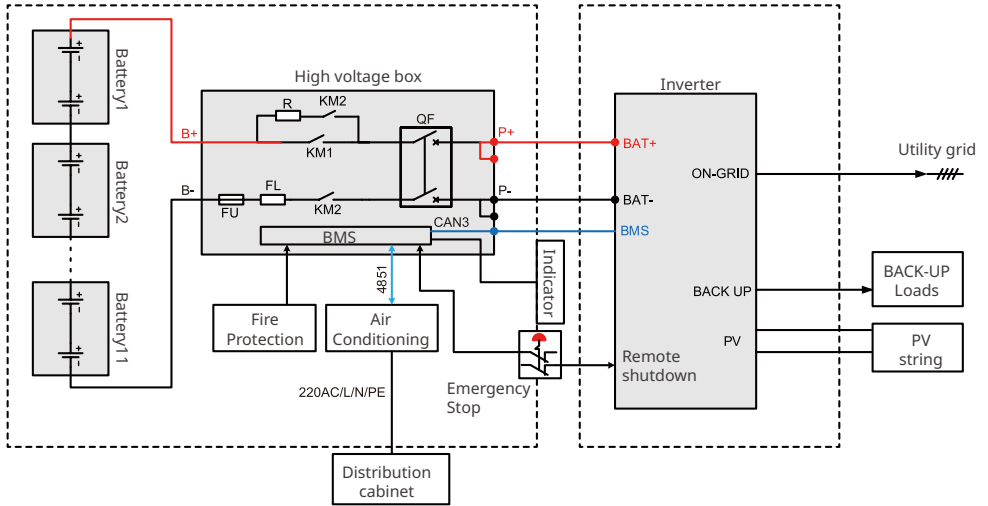

BMS System Architecture

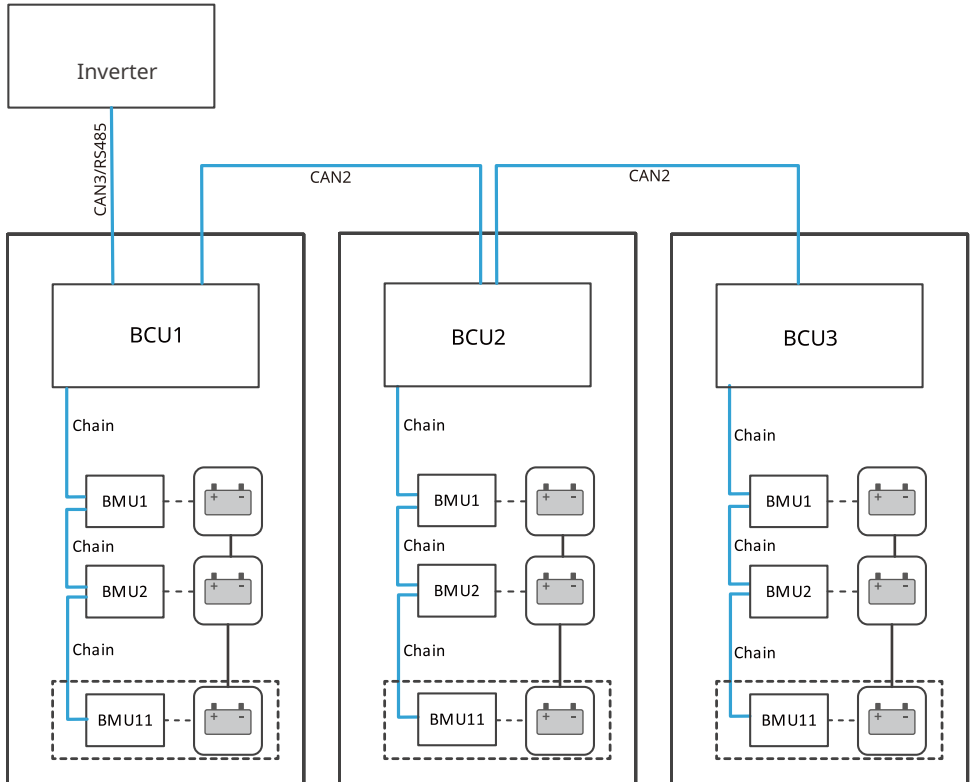

Battery System Expansion Description

NOTICE

- The product supports capacity expansion. A maximum of 3 battery systems can be used to extend the usable energy of the product. The expansion conditions must be strictly followed. For more information, please contact your dealer or equipment manufacturer. Failure to follow the requirements may result in an under-voltage, over-voltage difference fault in the battery system.
- When using multiple battery systems, the battery system directly connected to the inverter is the host system, and the rest are the slave systems.

60kWh



Battery System x1

120kWh

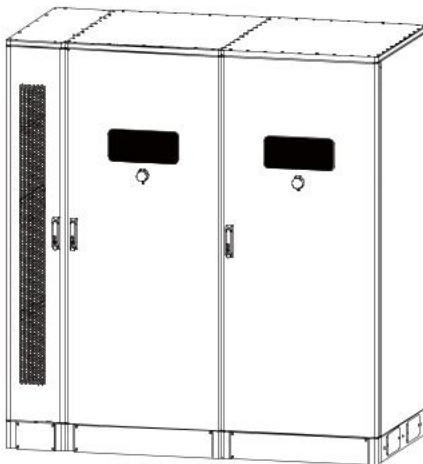

Battery System x2

180kWh

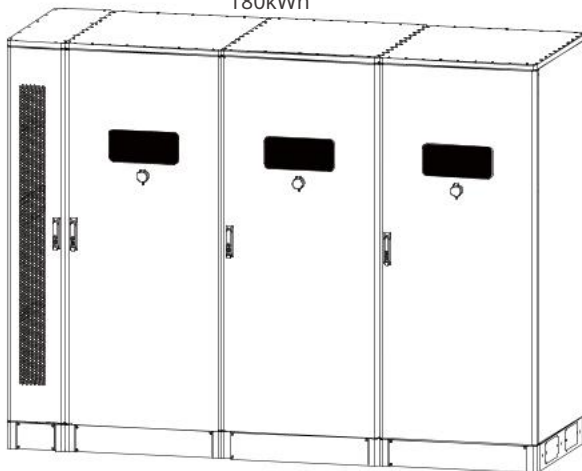

Battery System x3

3.2 Application Scenarios

NOTICE

- The product is suitable for small and medium-sized industrial and commercial scenarios. Factors such as: temperature, humidity, weather conditions, etc. may limit the battery's current and affect its load.
- The communication equipment is installed in a metal shell, thus the strength of communication signals will be attenuated, and the distance between the energy storage system and the router should not exceed 10 meters. After successful communication between the energy storage system and the router, it is necessary to confirm in the Solargo APP that the router displays a signal strength value greater than -60.

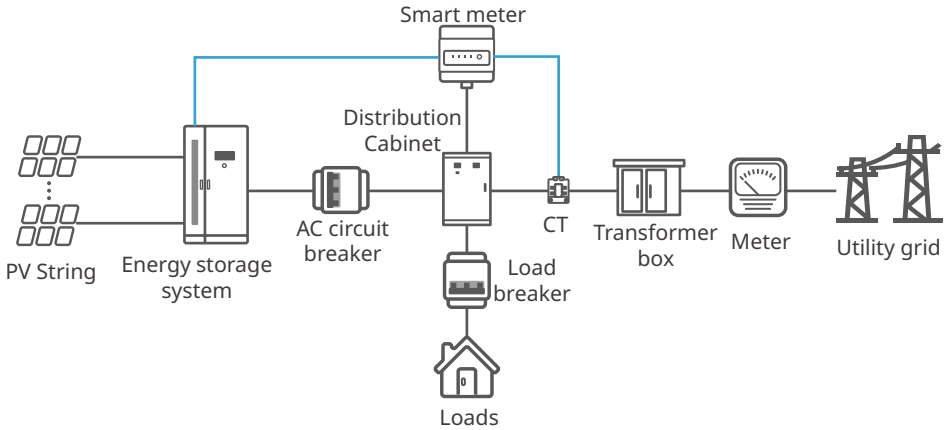

The inverter models used in conjunction with this energy storage system are as follows:

Energy storage system model	Inverter Model
GW60KWH-4H-A-10	GW15K-ET
GW60KWH-3H-A-10	GW20K-ET
GW60KWH-2H4-A-10	GW25K-ET
GW60KWH-2H-A-10	GW29.9K-ET/ GW30K-ET
GW60KWH-D-10	-

Inverter information can be obtained through the official website or by scanning the following QR code:



3.3 Features

Fire Fighting System

The battery system is equipped with perfluorohexane gas fire extinguishing devices and aerosol fire extinguishing agents. When a fire or other emergency occurs, the aerosol fire extinguishing agent inside the battery is first sprayed to suppress the fire. If the ambient temperature inside the battery system reaches the set temperature of the perfluorohexane gas fire extinguishing device, the temperature sensing glass ball of the fire extinguishing device will immediately burst, releasing the extinguishing gas from the nozzle assembly, thereby achieving cooling and fire extinguishing.

Intelligent Air Conditioning

The product is equipped with an integrated intelligent air conditioner, which can automatically detect the temperature and humidity inside the product, and perform corresponding refrigeration, heating, air supply, and dehumidification operations to ensure the normal operation of the system.

Air Conditioner Technical Parameters	
Cooling Power	1.5KW
Nominal AC Input Power Supply	220VAC~50Hz
Refrigeration capacity (L35/L35)	1500W
Nominal AC Input Power	595W
Nominal Current	2.9A
Heating Capacity	1000W
Air Volume	450 m ³ /h
Outline Dimensions of the Box (height * width * depth)	750*450*200mm
Outline Dimensions with Flange (height * width * depth)	784×484* 200mm
Weight (kg)	31kg
Mounting Method	Door mounted, embedded 35mm in the door
Maximum Sound Pressure Level Noise	64dB (A)
Ingress Protection Rating (Between Internal and External Circulation)	IP55
Refrigerant	R134a
Surface Treatment	Electrostatic spraying (RAL7035)

L35/L35: The temperature inside and outside the cabinet is 35 °C.

3.4 Appearance

3.4.1 Parts

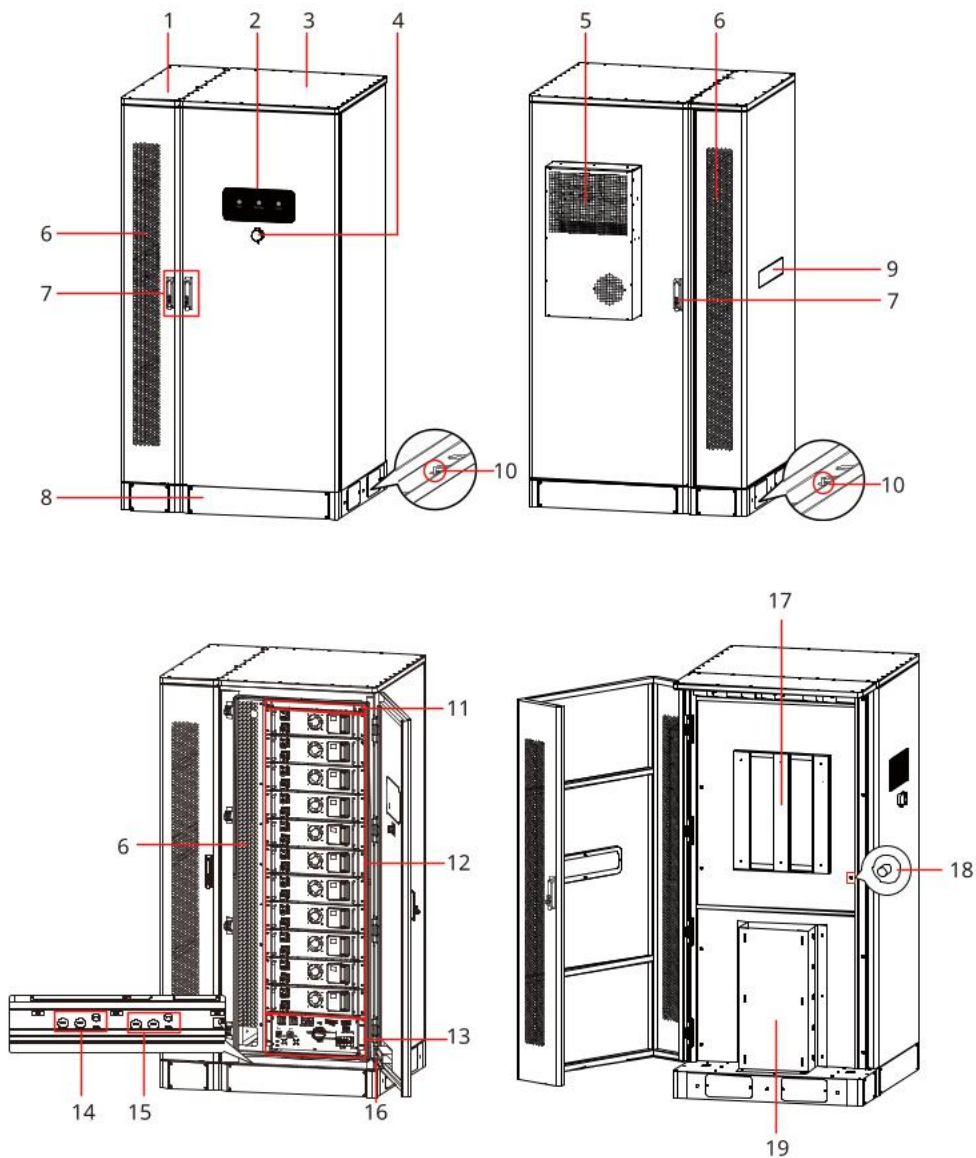

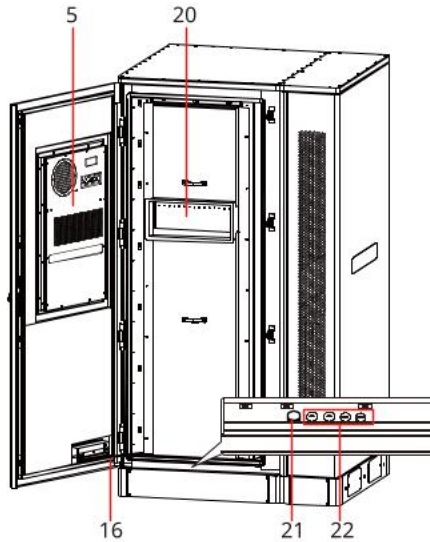

No.	Parts	Description
1	AC Unit	Position for installing inverter.
2	Indicator	Indicates the operational status of the energy storage system.
3	Battery system	Includes battery module, high-voltage box, fire protection device, and air conditioning.
4	Emergency Stop Button	This button can be used to stop the system from running when an emergency occurs.
5	Air Conditioner	Adjust the temperature and humidity of the energy storage system.
6	Heat Sink	Used for heat dissipation in energy storage system.
7	Door Lock	-
8	Base	Used for transportation, wiring, and fixing to the ground.
9	Display window of the inverter indicator	The status of indicator light of the inverter can be seen through this window.
10	PE terminal	Connects the grounding cable..
11	Fire Fighting Device	When a fire or other emergency occurs, it can suppress the fire, protect the system and personal safety.
12	Battery Modules	Used for storing and releasing power.
13	Power Control Unit	It is used to connect the battery module and the inverter, and it can control the power supply and power outage of the battery module.

No.	Parts	Description
14	Cable Hole for Inverter	-
15	Cable Hole for Parallel Connection	-
16	Limit Rod	-
17	Mounting Bracket for Inverter	Used to mount the inverter.
18	Grounding Point of the Inverter	Connects the grounding cable.
19	Inverter Wiring Channel	Used for inverter cable routing.
20	Air Inlet	For air conditioning air supply.
21	Explosion Proof Valve	When an explosion occurs in the energy storage system, the impact force is first released from the explosion-proof valve to prevent injury to nearby personnel.
22	Air Conditioning Cable Hole	-

Introduction to Battery Components

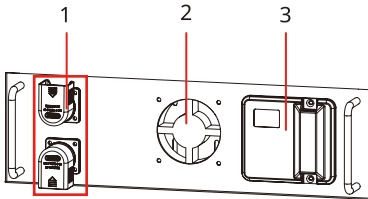

No.	Parts	Description
1	Power Connector	Used for power connection between batteries and batteries, batteries and high-voltage boxes.
2	Fan	Used for cooling the battery module.
3	Battery Pack Management Unit	Used for communication between batteries and batteries, batteries and power control unit.

Introduction to Power Control Unit Components

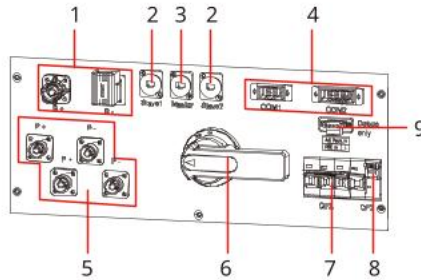

No.	Parts	Description	No.	Parts	Description
1	Power Connector	Used for power connection between batteries and power control unit.	6	Battery Cluster Switch	Control the power supply and power outage of the battery module.
2	Communication Port to Inverter	Used for connecting the inverter communication line.	7	DC Switch	Turn on or off DC power supply in the battery system.
3	Communication Port for Parallel Connection	When using more than one battery cabinets, the port will be used to connect the communication line between the battery systems.	8	External AC Switch	Turn on or off external AC power supply in the battery system.
4	Communication Port for Power Control Unit	Used for power control unit communicate with battery modules, inverters, fire protection devices, and air conditioners.	9	External AC Power Supply Port	Connect external AC power supply cables.
5	Power Output Port	Port for connecting inverter and battery.	-	-	-

Introduction to Fire Fighting System Components

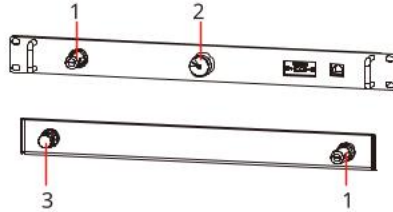





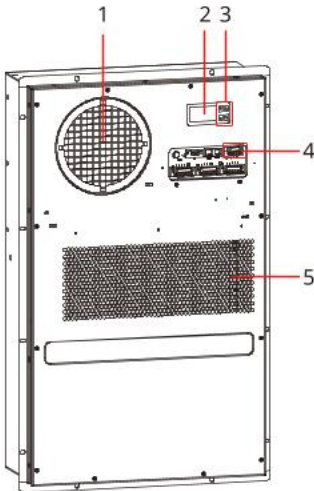





No.	Parts	Description
1	Thermo Bulb	It detects the temperature inside the energy storage system. When the temperature exceeds 79 °C, the thermo bulb will burst.
2	Main Valve & Pressure Gauge	<ul style="list-style-type: none"> The main valve is used to open the valve of fire fighting device. The pressure gauge is used to determine whether there is a leak in the extinguishing agent.
3	Nozzle	Used to spray fire extinguishing agent.

Introduction to Air Conditioning Components



No.	Parts	Description
1	Hot Air Inlet	-
2	Display Screen	Used to check air conditioning settings information.
3	Operation Buttons	Used to operate the display screen.
4	AC Power Input Port	Used for air conditioning power supply.
5	Used for air conditioning power supply.	-

3.4.2 Indicator Description

Indicator	Status	Description
 Run		ON = The equipment is working normally.
		BLINK 1 = The battery is operating normally and not communicating with the inverter.
		BLINK 2 = The device is in standby mode.
		Green Light OFF, Yellow Light ON = The equipment is warning. Green Light OFF, Red Light ON = A fault has occurred. All Lights OFF = The equipment is not powered on.
 Warning		ON = The equipment is warning.
		OFF = The equipment is not warning.
 Fault		ON = A fault has occurred.
		OFF = The equipment is not warning.

3.4.3 Dimension

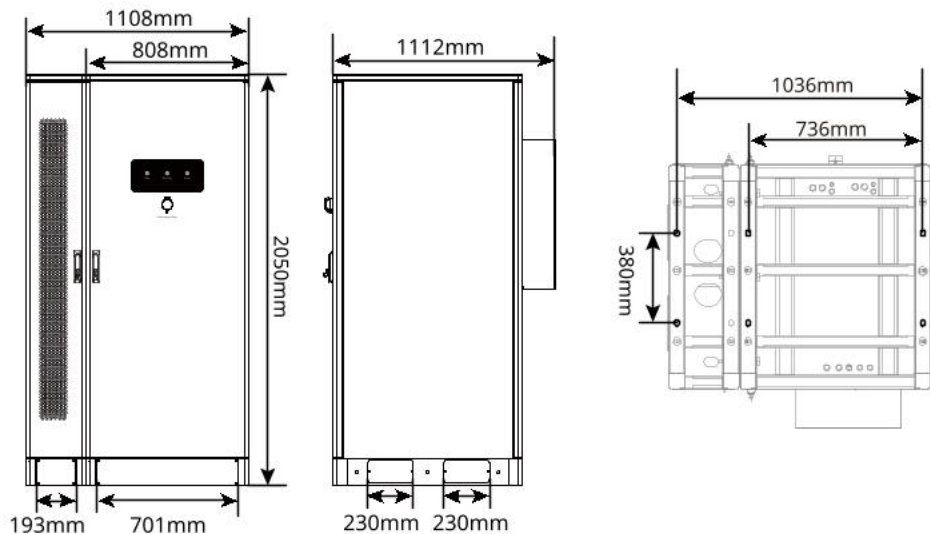

3.4.4 Nameplate

The nameplate is for reference only.

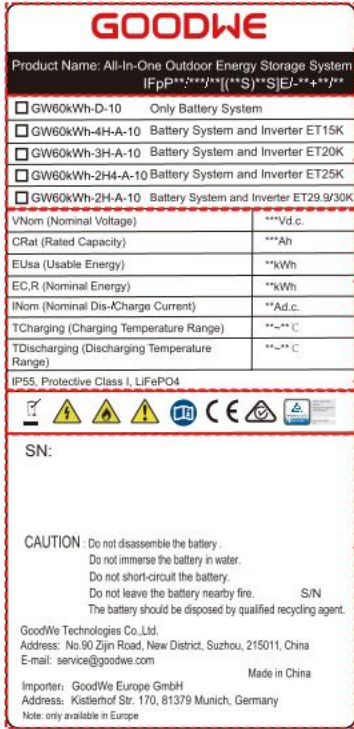

GW trademark, product type, and product model

Product model

Technical parameters

Safety symbols and certification marks

Contact information and serial number

4 Check and Storage

4.1 Check Before Receiving

Check the following items before receiving the product.

1. Check the outer packing box for damage, such as holes, cracks, deformation, and other signs of equipment damage. Do not unpack the contents from the box and contact the supplier as soon as possible if any damage is found.
2. Check the product model. If the model is not what you requested, do not unpack the product and contact the supplier.
3. Check the deliverables for correct model, complete contents, and intact appearance. Contact the supplier as soon as possible if any damage is found.

4.2 Deliverables



WARNING

Please use the wiring terminals shipped in the attachment. If the wiring terminals used do not meet the specifications, the manufacturer shall not be liable for any damage caused by it.

NOTICE

[1]: Only models GW60KWH-4H-A-10, GW60KWH-3H-A-10, GW60KWH-2H4-A-10 and GW60KWH-2H-A-10 are equipped with power cables from inverters to power control unit, wiring terminals between inverters and batteries, and communication cables from inverters to power control unit.

[2]: Only model GW60KWH-D-10 product is equipped with terminal resistors.

[3]: For GW60KWH-D-10: Connecting terminals for power control unit x 2, for others: Connecting terminals for power control unit x 1.

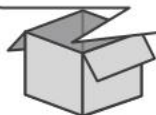
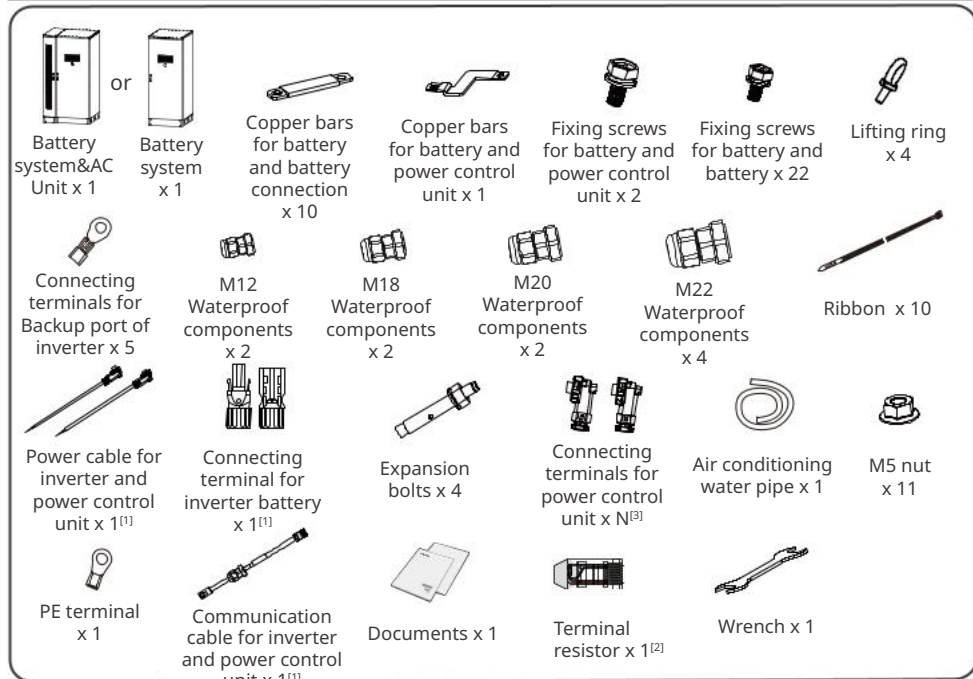

4.3 Storage

If the equipment is not to be installed or used immediately, please ensure that the storage environment meets the following requirements:

1. Do not unpack the outer package or throw the desiccant away.
2. It is recommended to complete the equipment installation within 3 days after removing the packaging box. If the equipment is not installed, it needs to be repackaged using the original packaging box for storage.
3. Ensure that equipment is stored away from flammable, explosive, and corrosive materials.
4. Ensure that the device is stored in a cool and shaded area, avoiding direct sunlight.
5. Store the equipment in a clean place. Make sure the temperature and humidity are appropriate and no condensation.
6. When storing, it is recommended that the SOC range of the battery be between 30% and 50% SOC. Every 3 months, the battery should have a charge and discharge cycle.
7. Storage Temperature Description(°C)
 - When the temperature is between -20 °C and 0 °C, the storage time cannot exceed 1 month.
 - When the temperature is between 0 °C and 35 °C, the storage time cannot exceed 1 year (optimal storage temperature range: 20 °C ≤ temperature ≤ 30 °C).
 - When the temperature is between 35 °C and 45 °C, the storage time cannot exceed 1 month.
8. Storage humidity range requirement: 0~95% RH without condensation. If moisture condensation is found at the battery interface, the battery system should not be installed.

5 Installation

5.1 Installation Requirements

Installation Environment Requirements

1. Do not install the equipment in a place near flammable, explosive, or corrosive materials.
2. Equipment should be kept away from environments where toxic and harmful gases are concentrated.
3. Do not install the equipment in a place that is easy to touch, especially within children's reach. High temperature exists when the equipment is working. Do not touch the surface to avoid burning.
4. Install the equipment in a sheltered place to avoid direct sunlight, rain, and snow.
5. The place to install the equipment shall be well-ventilated for heat dissipation and large enough for operations.
6. The equipment with a high ingress protection rating can be installed indoors or outdoors. The temperature and humidity at the installation site should be within the appropriate range.
7. During construction and installation, it should be ensured that the bottom of the equipment is above the highest water level in local history.
8. When the equipment is installed indoors, there should be no obstacles within a diameter of 10m at the installation location, and stay away from residential areas to prevent noise pollution.
9. The installation space of the equipment should be convenient for operation and maintenance, ensuring that the equipment indicator lights and all labels are easy to view.
10. The altitude to install the product shall be lower than the maximum working altitude 4000m
11. Install the equipment away from electromagnetic interference. If there is any radio or wireless communication equipment below 30MHz near the equipment, please ensure that the distance between the battery and the wireless electromagnetic interference equipment is greater than 30m.

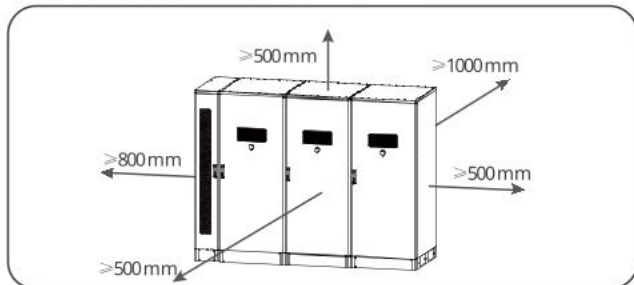

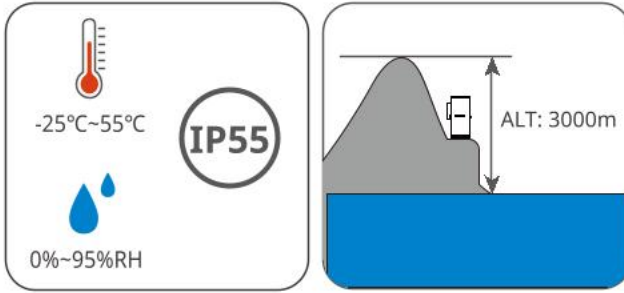

Foundation Requirements

- The foundation must be flat and dry, and cannot be sunken or tilted. It is strictly prohibited to install in a stagnant environment.
- Install the equipment on a surface that is solid enough to bear the inverter weight.
- The foundation material must be concrete or other nonflammable surfaces.
- The foundation needs to reserve trenches or outlet holes to facilitate equipment wiring.
- The equipment installation (including height, embedded parts of expansion screws, threading pipes, etc.) can be adjusted on-site.
- The height of the equipment foundation top mark can be adjusted according to the actual needs of the equipment and the site.
- Trench requirements:
 1. The equipment adopts a bottom inlet line, and the trench must have a dust-proof and rodent proof design to prevent foreign objects from entering.
 2. Waterproof and moisture-proof is a must in the trench to prevent cable aging and short circuit, which may affect the normal operation of the equipment
 3. Due to the thick cables of the equipment, sufficient space for cables needs to be reserved in the trench design to ensure smooth connection and no abrasion.

NOTICE

The conduit can be replaced with 4 PVC pipes with a diameter of 125mm on site, and there is no need to reserve conduit for indoor environments.

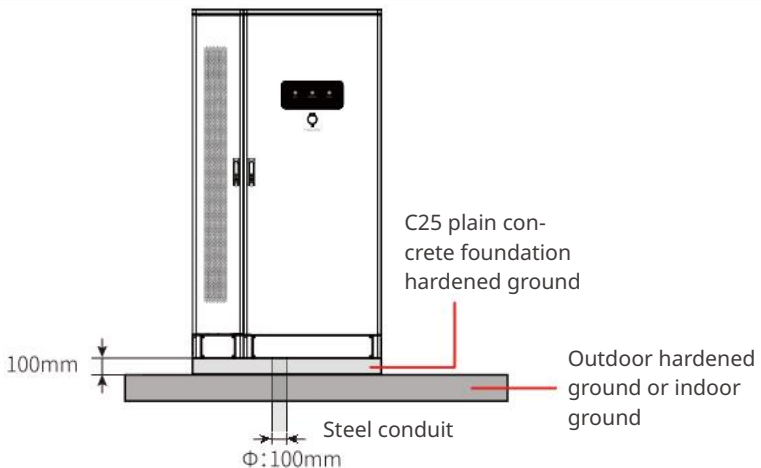

Installation Angle Requirements

Make sure the equipment is installed vertically and not tilted or upside down.

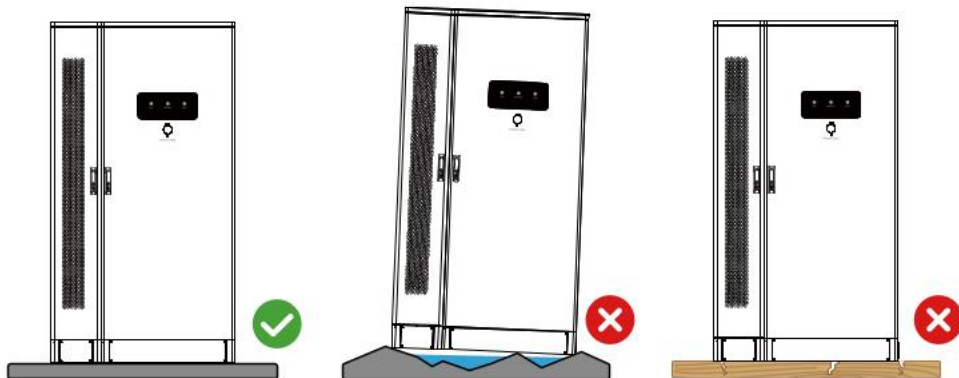

Installation Tool Requirements

The following tools are recommended when installing the equipment. Use other auxiliary tools on site if necessary.



5.2 Equipment Installation

5.2.1 Handling Equipment

CAUTION

- Operations such as transportation, shipment, installation and so on shall in compliance with the laws and regulations of the country or region where the inverter is located.
- Move the equipment to the site before installation. Follow the instructions below to avoid personal injury or equipment damage.
 1. Consider the weight of the equipment before moving it. Assign enough personnel to move the equipment to avoid personal injury.
 2. Keep balance to avoid falling down when moving the equipment.
 3. Ensure that the cabinet door is securely locked during equipment handling.

NOTICE

- The equipment can be transported to the installation site by hoister or forklift.
- When choosing to lift the equipment, please use flexible lifting straps or tie, and the load-bearing capacity of a single strap needs to be $\geq 2t$.
- When using a forklift to transport equipment, the load-bearing capacity of the forklift needs to be $\geq 2t$.

Expansion bolt installation

Step 1: Mark the positions for drilling holes on a level ground.

Step 2: Use an impact drill with a drill bit diameter of 14mm to drill holes, ensuring a depth of approximately 80mm, and install expansion bolts.

Step 3: Transport the equipment to the hole location and tighten the expansion bolts using a socket wrench.

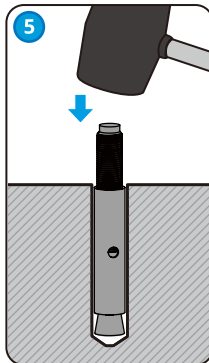
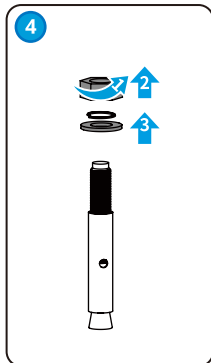
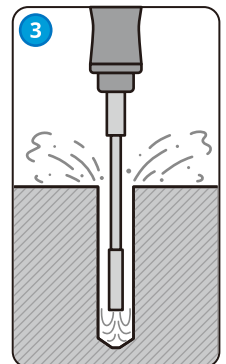
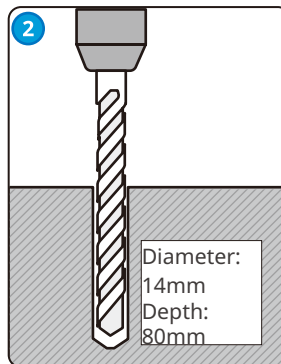
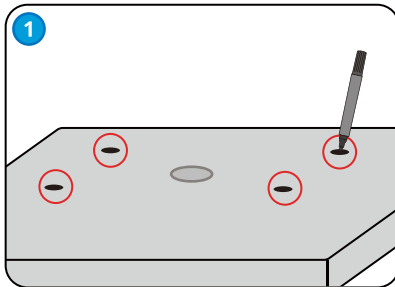

Forklift lifting (optional)

Method I

Step 1: Remove the front plate at the bottom of the equipment.

Step 2: Use a forklift to transport the equipment, shift the center of gravity of the equipment towards the battery system, and maintain equipment balance.

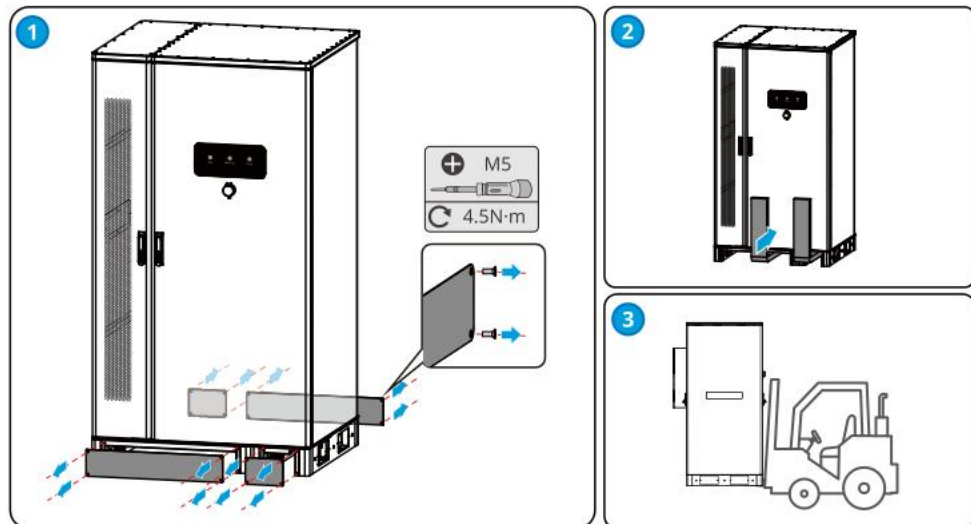

Method II

Step 1: Remove the plates on both sides of the bottom of the equipment.

Step 2: Use a forklift to transport the equipment and maintain its balance.

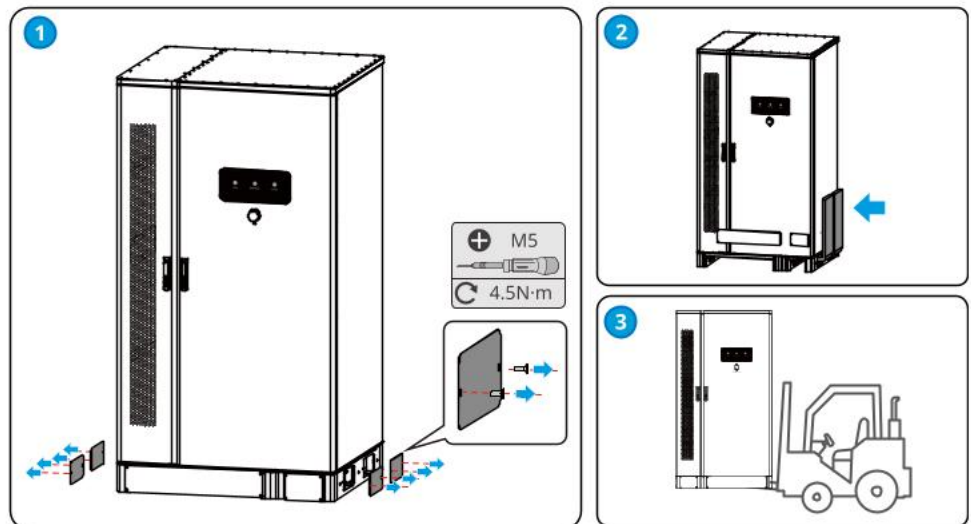

Hoister lifting (optional)

Step 1: Remove the upper cover plate of the equipment.

Step 2: Install lifting rings.

Step 3: Use a lifting device to lift and transport the equipment.

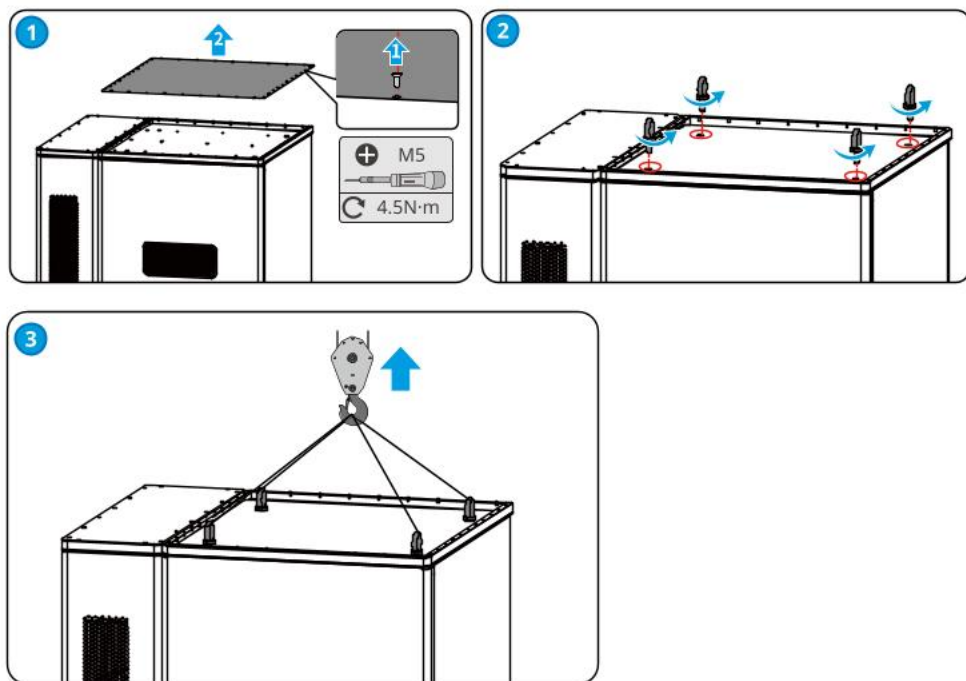

Fixing the equipment

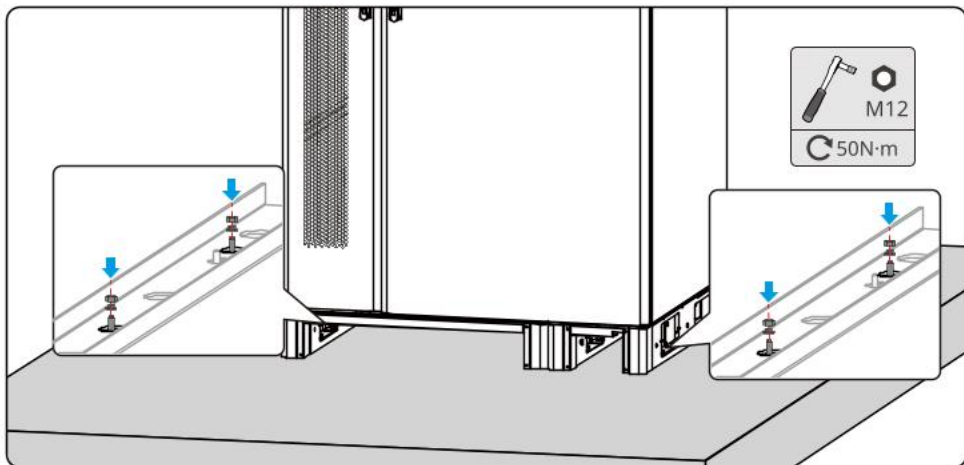

Open the cabinet door

NOTICE

Please use the key shipped with the equipment to open the cabinet door.

Step 1: Use the key to unlock the cabinet door.

Step 2: Rotate the door handle to open the cabinet door.

Battery system

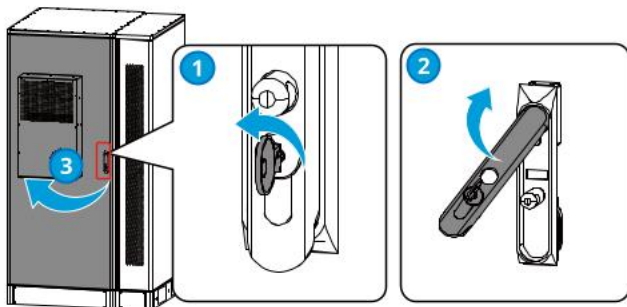
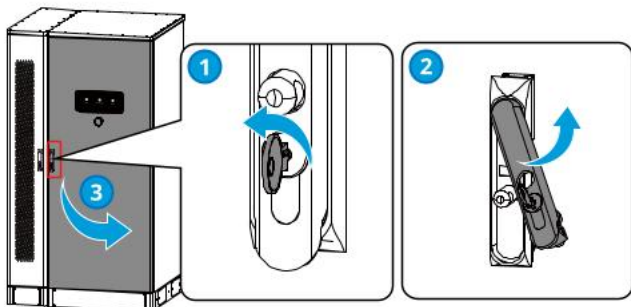

AC Unit

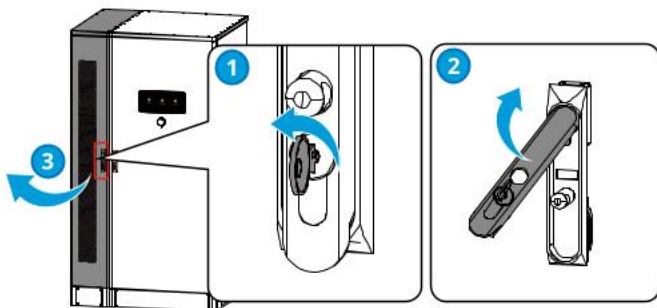

Inverter Installation

NOTICE

- Make sure the inverter is firmly installed in case of falling down.
- The DC switch lock is provided by customers, with an aperture of: \varnothing 5mm, please choose a suitable DC switch lock, otherwise it may cause installation failure.

Step 1: Fix the inverter back mounting bracket on the mounting bracket.

Step 2: (Optional) Secure the DC switch with the DC switch lock, ensuring that the DC switch is "OFF" during installation.

Step 3: Install the inverter on the mounting plate. Install the inverter on the mounting plate. For models equipped with handles, please use the handle to lift the inverter; For models without handles, please lift the inverter directly.

Step 4: Tighten the nuts to secure the mounting plate and the inverter.

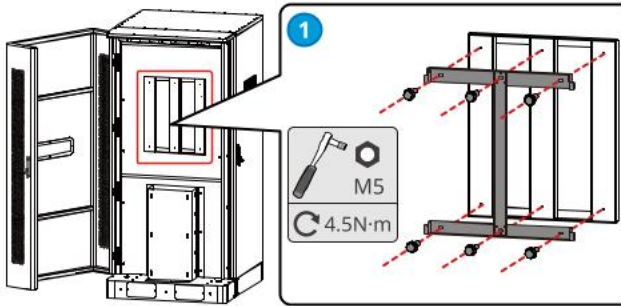

3 With handles

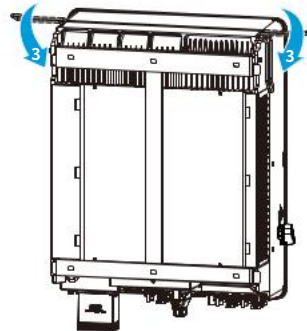
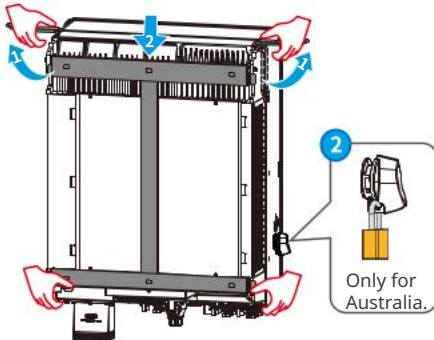

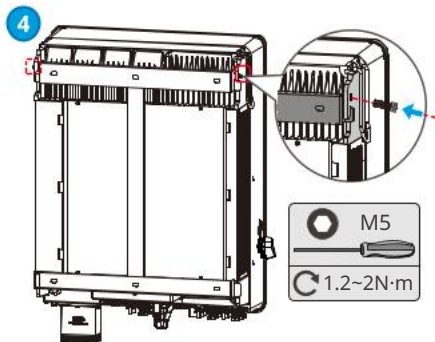
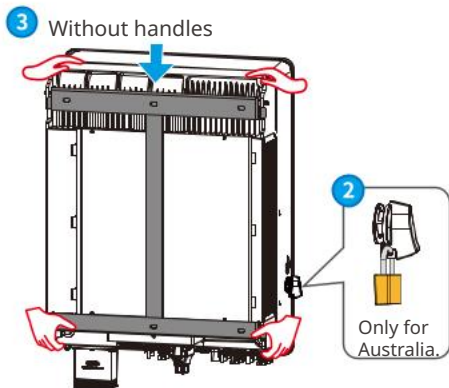

6 Electrical Connection

6.1 Safety Precaution

DANGER

- The battery system belongs to a high-voltage system, and there is high voltage when the equipment is running. Before operating the equipment in the system, please ensure that the equipment has been powered off to avoid the risk of electric shock. Please strictly follow all safety precautions in this manual and the safety signs on the equipment during the operation of the equipment.
- Perform electrical connections in compliance with local laws and regulations. Including operations, cables, and component specifications.
- Please ensure that all superior switches of the energy storage system are disconnected before connecting electrical cables, .
- Before making electrical connections, disconnect the switch of battery cluster of energy storage system and switch of DC power supply to ensure that the equipment has been powered off. Do not work with power on. Otherwise, an electric shock may occur.
- Tie the cables of the same type together, and place cables of different types apart. Do not place the cables entangled or crossed.
- If the tension is too large, the cable may be poorly connected. Reserve a certain length of the cable before connecting it to the equipment's cable port.
- Make sure that the cable conductor is in full contact with the terminal and the cable insulation part is not crimped with the terminal when crimping the terminal. Otherwise, the equipment may not be able to work properly, or the connection may be unreliable during working, which may cause terminal block damage, etc.

NOTICE

- Wear personal protective equipment like safety shoes, safety gloves, and insulating gloves during electrical connections.
- All electrical connections should be performed by qualified professionals.
- Cable colors in this document are for reference only. The cable specifications shall meet local laws and regulations.
- Please refer to the inverter user manual for detailed wiring methods for remote shutdown on the inverter side.

Single Battery System

NOTICE

When using a single battery system, the Slave2 communication port does not require the installation of terminal resistors.

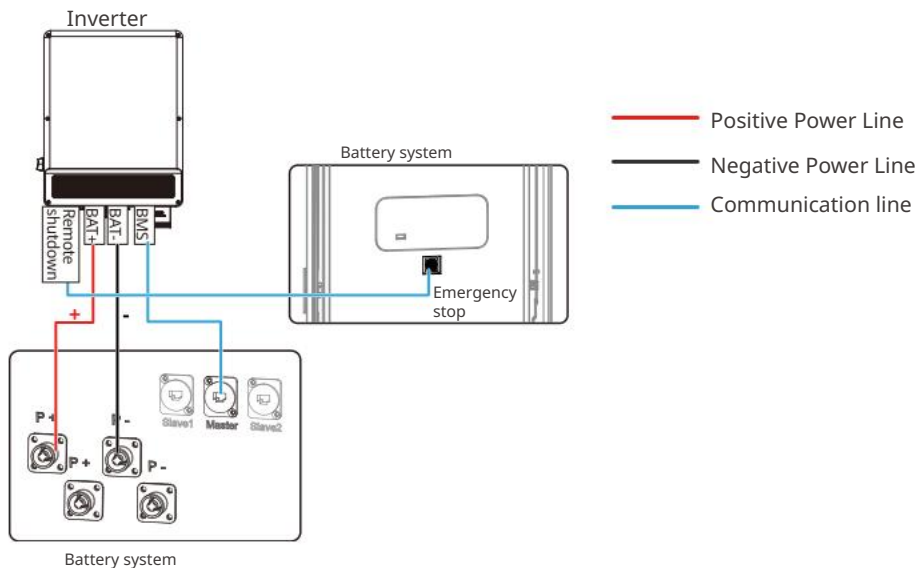

Multiple battery systems

NOTICE

- Please ensure that the Slave communication port of the last battery system has installed terminal resistor. If the terminal resistor is not installed, it will result in abnormal communication between battery systems.
- To perform an emergency stop operation, the emergency stop switch of the host system (battery system 1) must be used, otherwise the inverter cannot be stopped.

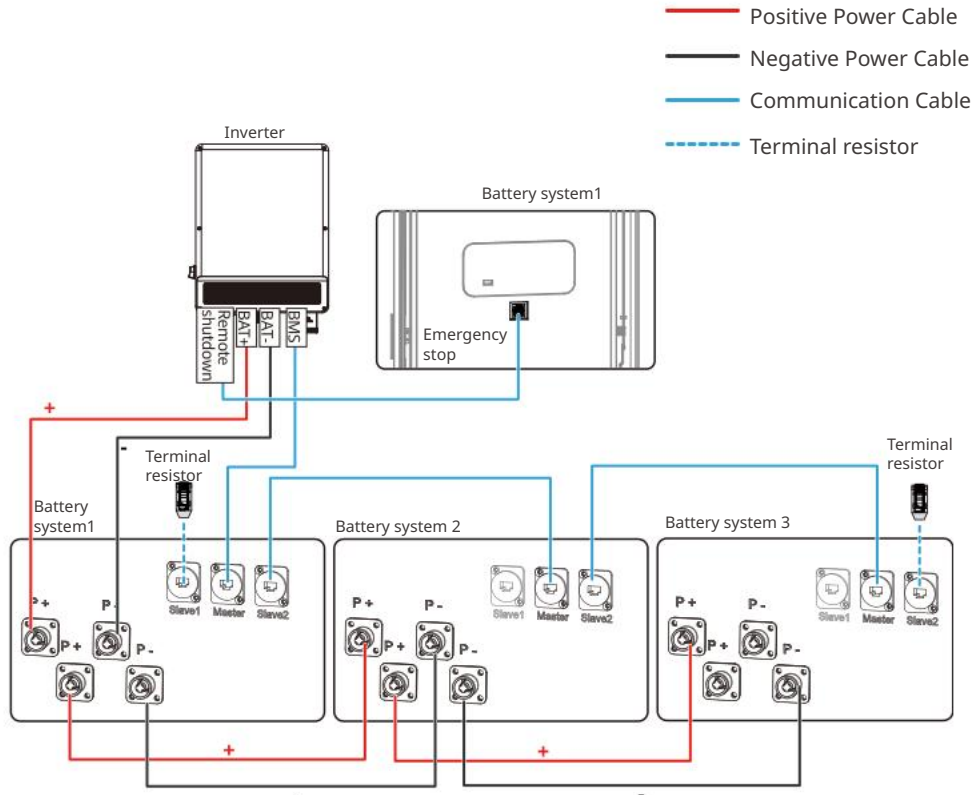

6.2 Connecting the PE cable

⚠ WARNING

- To improve the corrosion resistance of the terminal, it is recommended to apply silica gel or paint on the ground terminal after installing the PE cable.
- The grounding points on both sides of the energy storage system can be selected according to the actual site for grounding.
- The grounding cable should be prepared by customers.

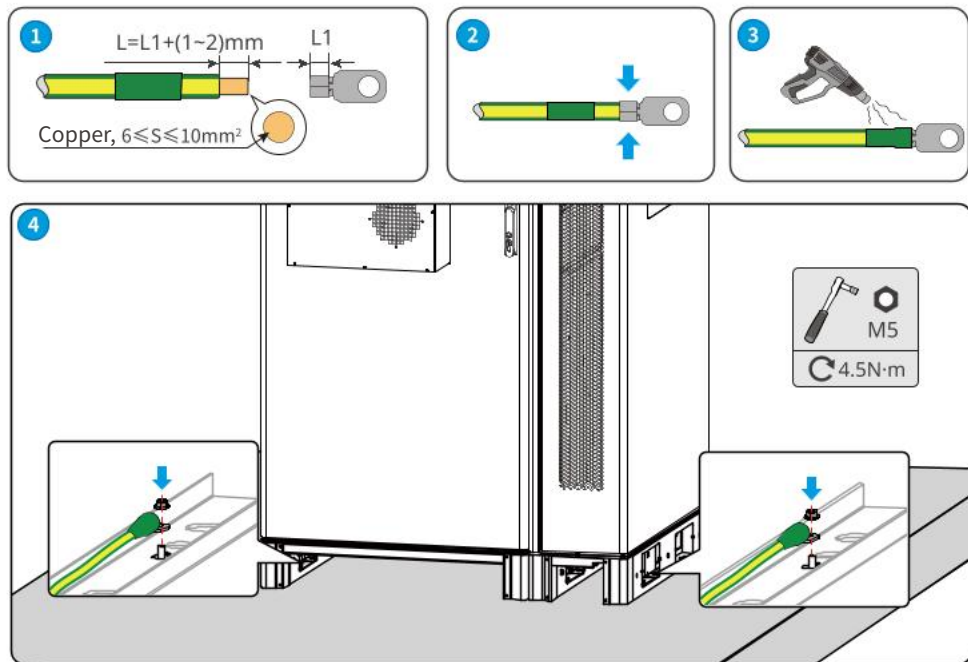

6.3 Connecting the battery cable

DANGER

- A short circuit in the battery may cause personal injury. The instantaneous high current caused by a short circuit can release a large amount of energy and may cause a fire.
- Before connecting the battery cable, please confirm that the battery module and high-voltage box are powered off, and that the battery cluster switch and DC power supply switch are both disconnected.
- It is forbidden to connect and disconnect the battery cables when the equipment is running. Otherwise it may cause electric shock.
- When connecting battery cables, use insulated tools to prevent accidental electric shock or short circuit to the batteries.
- Ensure that the open circuit voltage of the battery is within the permissible range of the equipment.

WARNING

- When wiring, ensure that the P+ of the power control unit is connected to the BAT+ of the inverter, and the P- of the power control unit is connected to the BAT- of the inverter. If the cable connection is incorrect, it will cause equipment damage.
- When wiring, avoid contact between the positive power line from the battery to power control unit and the negative power line from the battery to power control unit, otherwise it may cause damage to the battery system.
- Ensure that the cables are connected securely. Otherwise it will cause damage to the equipment due to overheat during its operation.

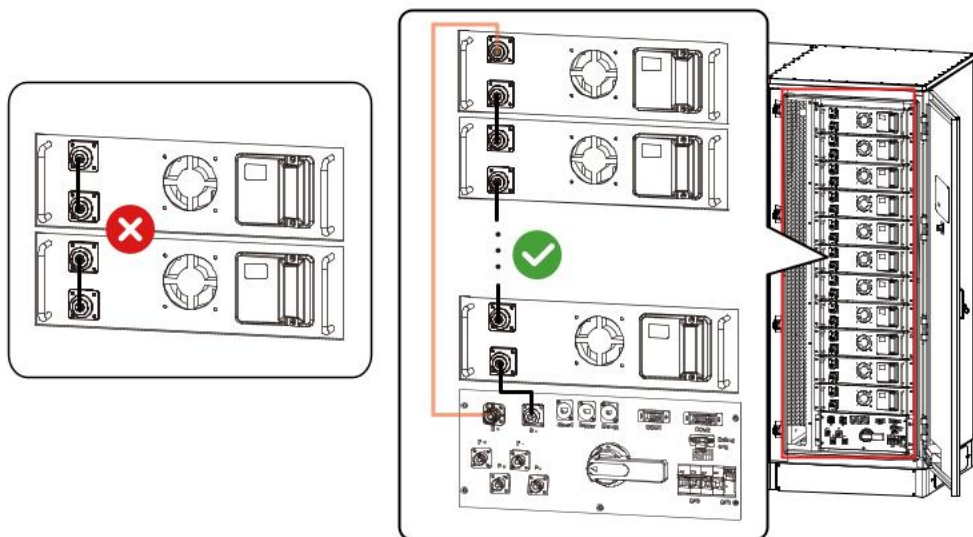

Steps for battery connection:

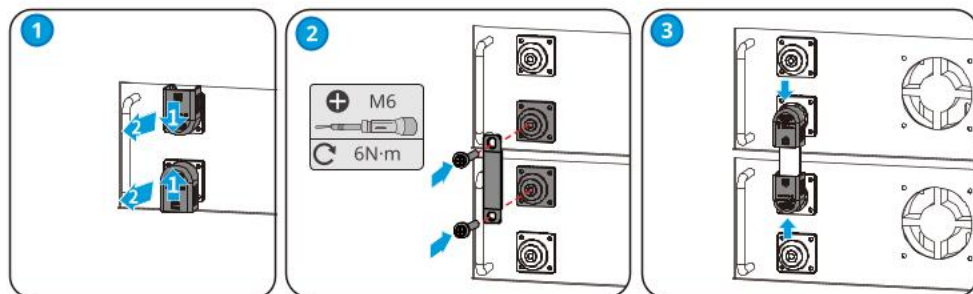

Steps for connecting the battery to the power control unit:

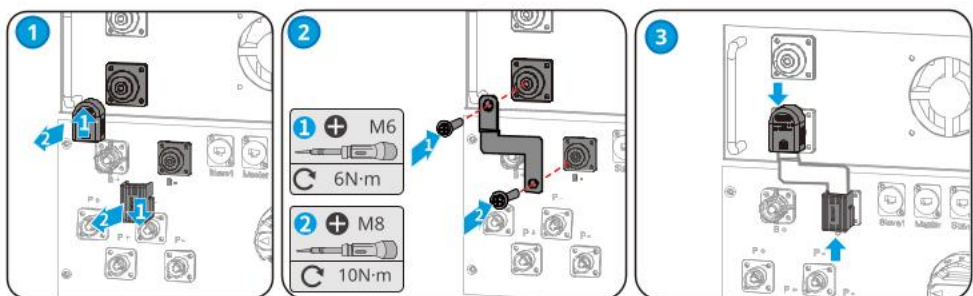

6.4 Connecting the power cable for air conditioning

NOTICE

- It is recommended to connect the air conditioning power cable to the distribution cabinet.
- To ensure that the air conditioner can be safely disconnected from the distribution cabinet in case of abnormal situations, please connect an AC switch between the air conditioner and the distribution cabinet. The specification of the AC switch should not be less than 16A.
- If the air conditioning needs emergency power supply, the air conditioning power cord can be connected to the BACK UP side of the inverter for power supply.

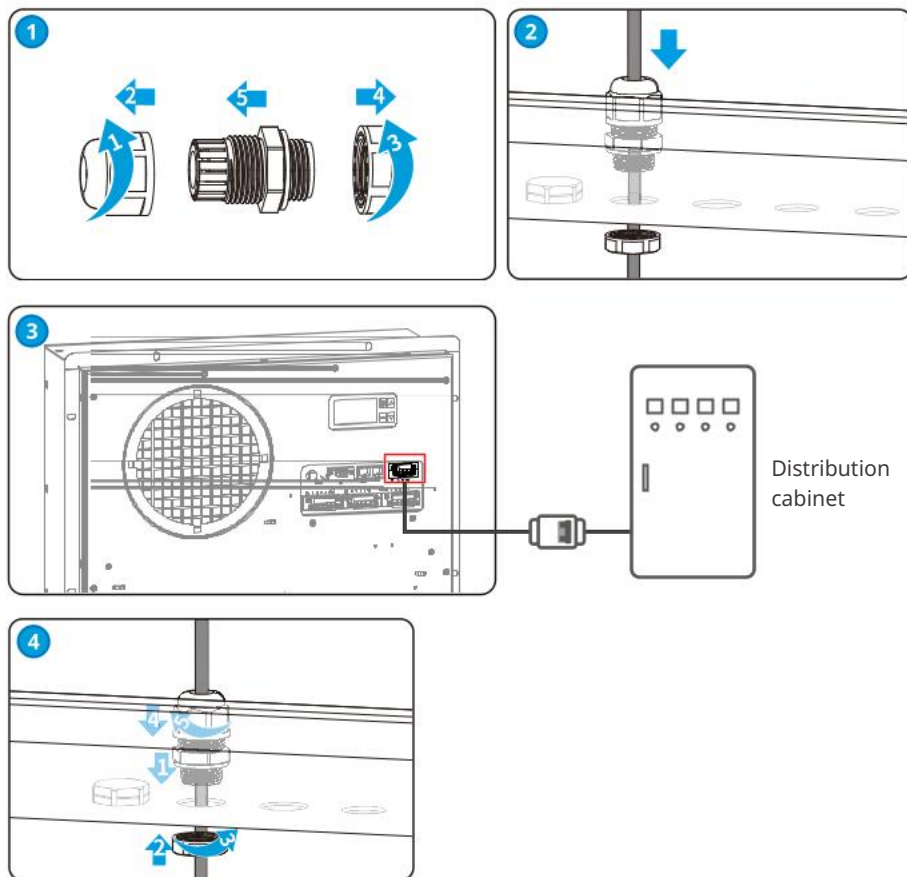

NOTICE

If the length of the air conditioning power cable equipped with the equipment is not long enough, customers need to prepare additional power cable. The cable requirements and wiring methods are as follows:

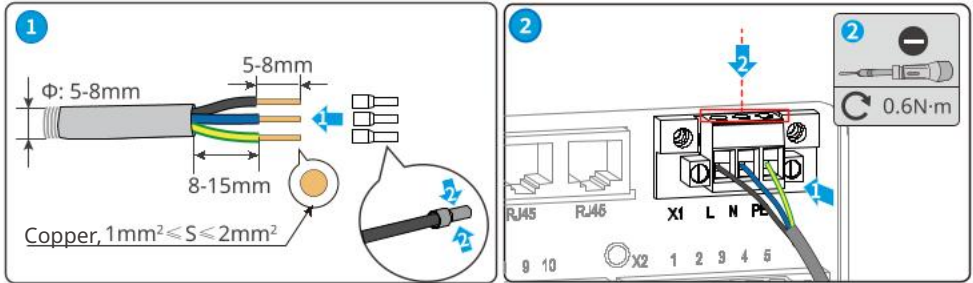

6.5 Connect the inverter to the power control unit

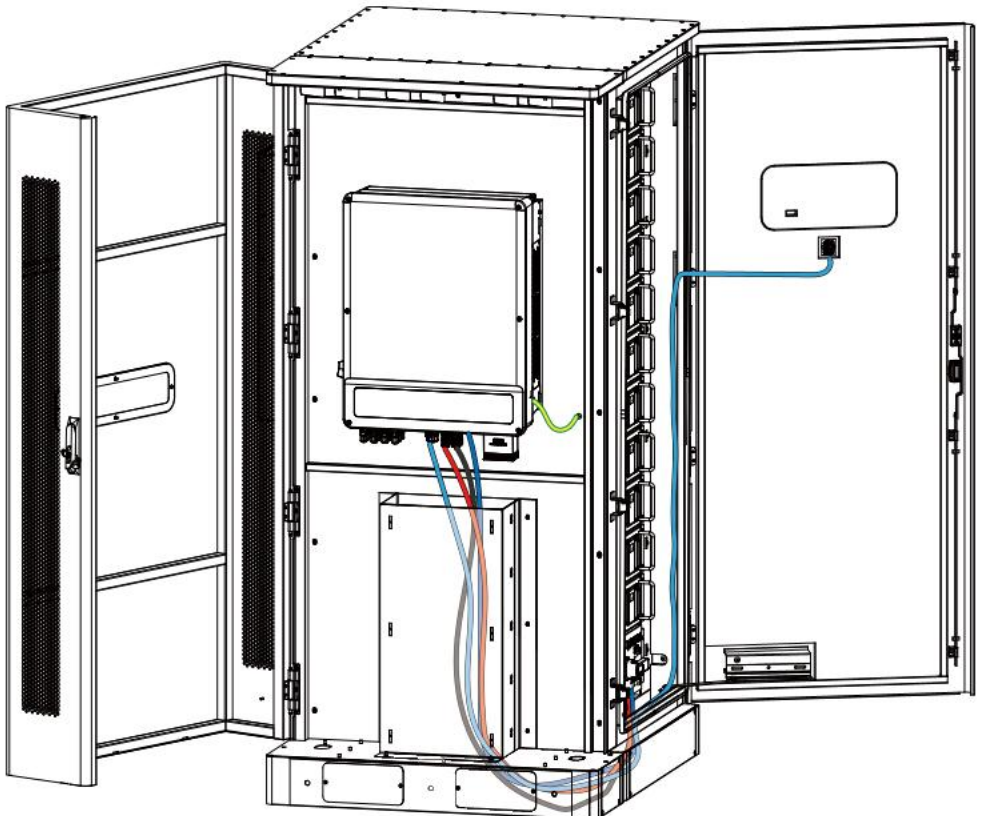

For detailed wiring methods on the inverter side, please refer to the ET Series 15-30kW User Manual.

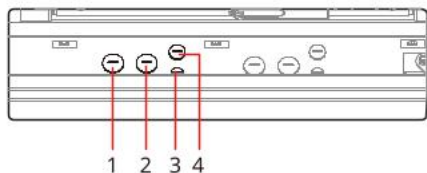

1. Hole for the positive pole power cable of the inverter
2. Hole for the negative pole power cable of the inverter
3. Hole for the communication cable to remotely shutdown the inverter
4. Hole for the communication cable of the inverter

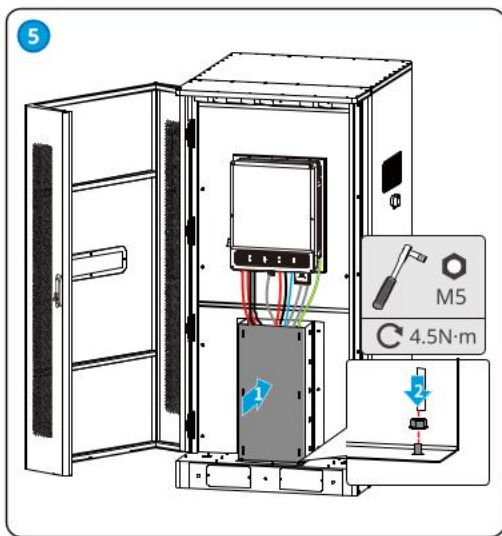
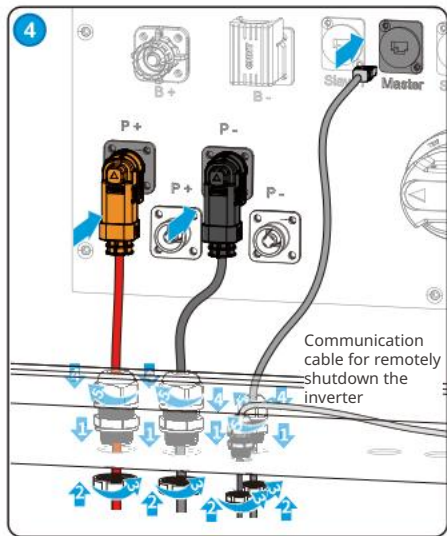
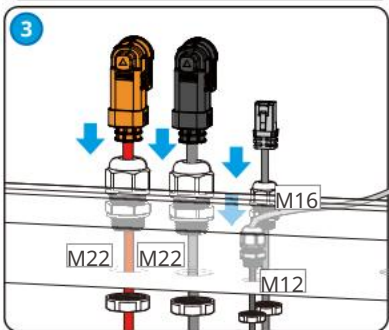
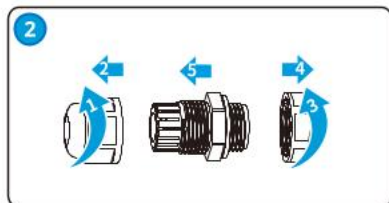
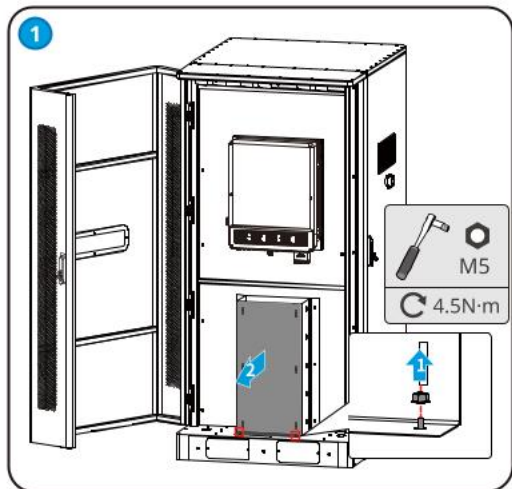

6.6 Multiple batteries wiring

NOTICE

When multiple batteries are connected in parallel, reserve communication cables for remote control of emergency stop switches in the slave system.

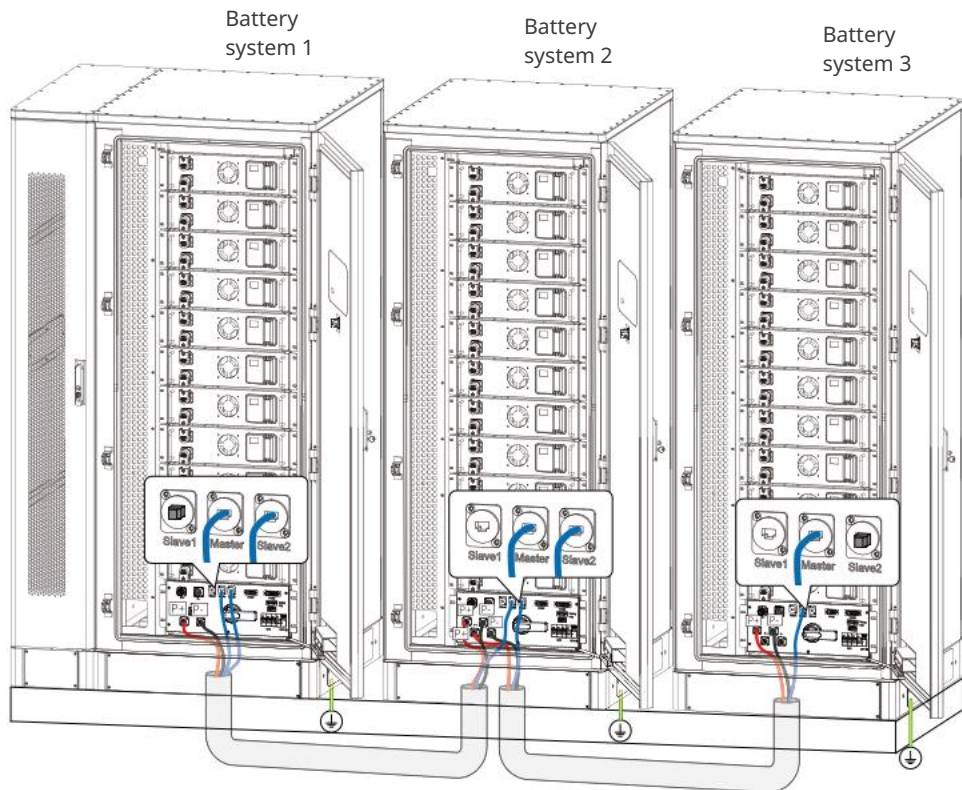

6.6.1 Making Power Cable

- Outdoor copper cable that meets 1500V standard.

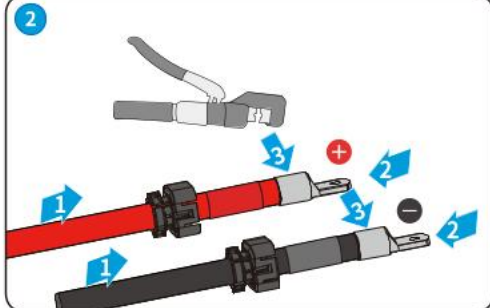
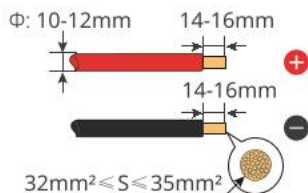

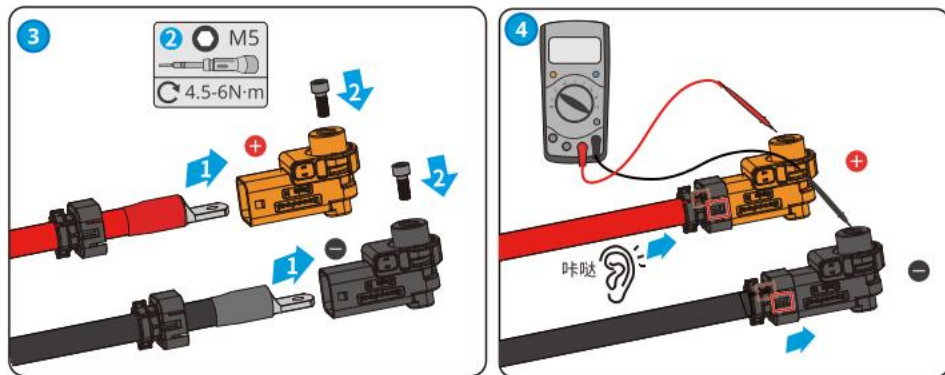

6.6.2 Making Communication Cable

NOTICE

- When multiple batteries are connected in parallel, the communication cables used should be prepared by customers, and it is recommended to use outdoor shielded twisted pair.
- PIN4,5 is only used for communication with inverter, and there is no need for crimping when using battery systems in parallel.

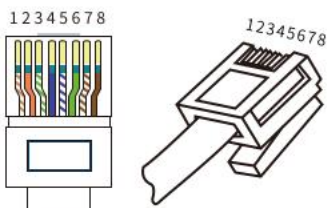

PIN	Master	Slave	Description
1	CAN2H	CAN2H	CAN communication for battery systems in parallel
2	CAN2L	CAN2L	CAN communication for battery systems in parallel
4	CAN3H	-	Communicates with inverter
5	CAN3L	-	Communicates with inverter
3, 6, 7, 8	-	-	Reserved

6.6.3 Terminal Resistor Connection

WARNING

- Please refer to the system wiring network for the installation requirements of terminal resistors in the battery system. This chapter only introduces the connection method of terminal resistors.
- If the terminal resistor is not installed, it will result in abnormal communication between battery systems.

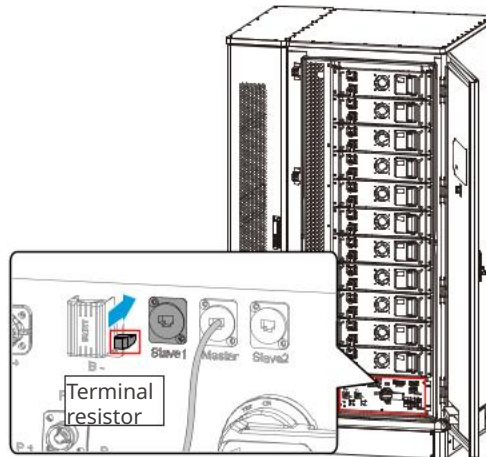

7 Equipment Commissioning

7.1 Check Before Power ON

No.	Check Item
1	The product is firmly installed at a clean place that is well-ventilated and easy-to operate.
2	The protective ground wire, battery power line, energy storage system cable, and air conditioning power line are connected correctly and firmly.
3	Cable ties are intact, routed properly and evenly.
4	The unused port has been blocked.
5	The battery cluster switch and DC power switch have been disconnected.
6	The voltage and frequency at the connection point meet the grid connection requirements.

7.2 Open fire fighting device

Step 1: Use a 14mm wrench to turn the screw behind the pressure gauge all the way counterclockwise, and the fire fighting device will be successfully opened.

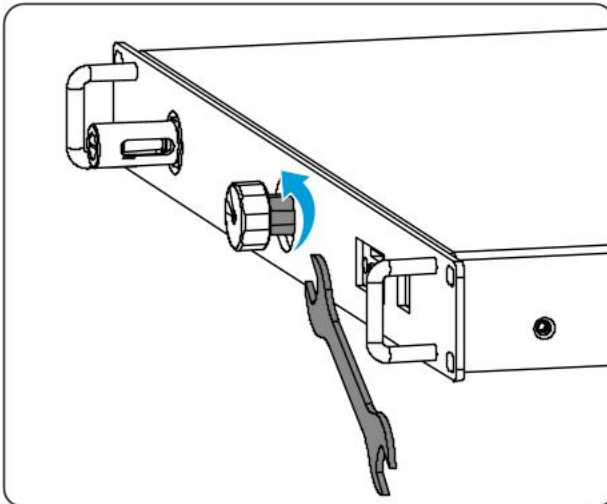

7.3 Power On

NOTICE

- When multiple batteries are connected in parallel, only the master battery can carry out black start, and the slave battery needs to be manually powered on.
- If the battery system fails to communicate with the inverter within 10 minutes, the black start will fail, and the battery cluster switch and DC power switch will automatically disconnect.

Single Battery system

Step 1: Connect the AC switch.

Step 2: Connect the DC power supply switch.

Step 3: Connect the battery cluster switch.

Step 4: Power on the inverter used in the system. Please refer to the corresponding inverter user manual for detailed operations.

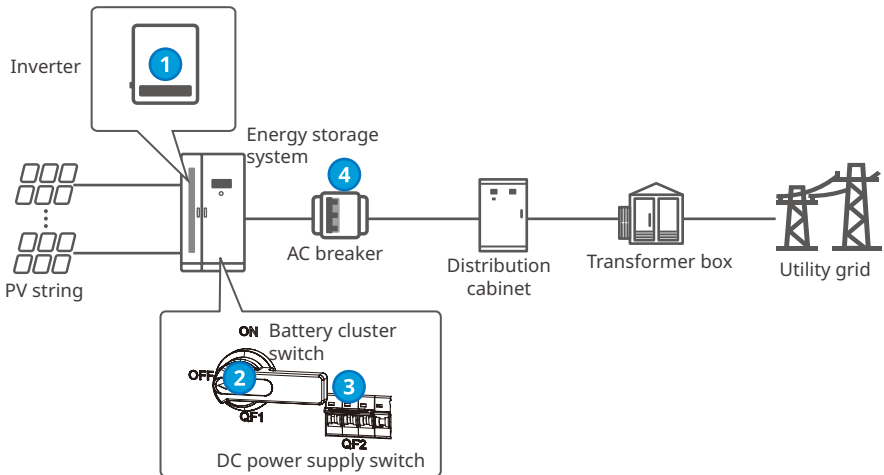

Power ON



Parallized battery systems

WARNING

- Before connecting battery cluster switch **4**, please ensure that the SolarGo App has correctly displayed the number of parallel clusters in the battery system, otherwise it may cause battery damage.

Step 1: Connect the AC switch.

Step 2: Connect the DC power supply switch of all battery systems within 5 minutes.

Step 3: Connect the battery cluster switch of battery system 1.

Step 4: Connect the battery cluster switch of battery system 2, 3.

Step 5: Power on the inverter used in the system. Please refer to the corresponding inverter user manual for detailed operations.

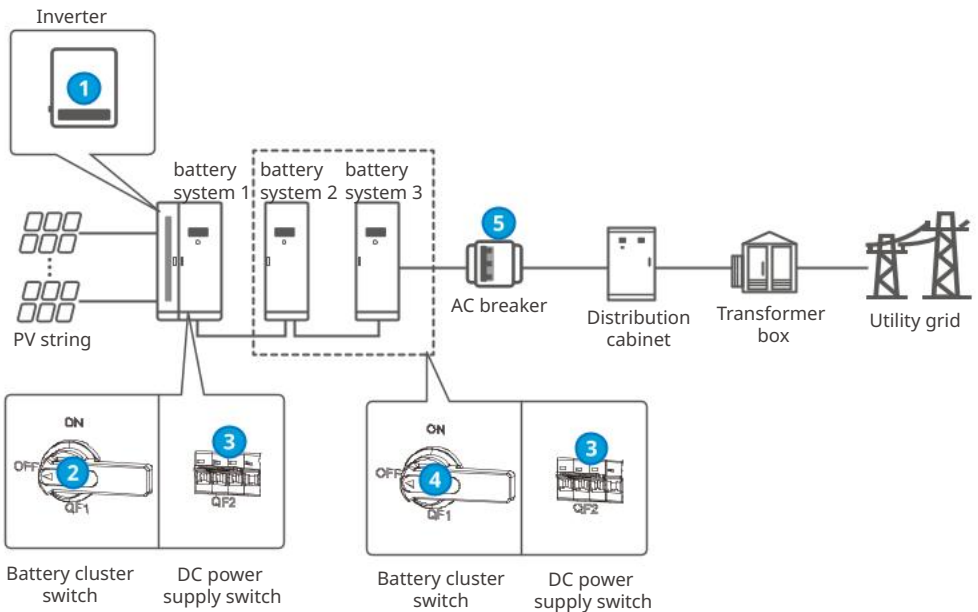











Power ON

Power on: **5** → **3** → **2** → **4** → **1**

8 System Commissioning

8.1 Indicators and Buttons

Indicator	Status	Description
 Run		ON = The equipment is working normally.
		BLINK 1 = The battery is operating normally and not communicating with the inverter.
		BLINK 2 = The device is in standby mode.
		Green Light OFF, Yellow Light ON = The equipment is warning. Green Light OFF, Red Light ON = A fault has occurred. All Lights OFF = The equipment is not powered on.
 Warning		ON = The equipment is warning.
		OFF = The equipment is not warning.
 Fault		ON = A fault has occurred.
		OFF = The equipment is not warning.

8.2 Setting Battery System Parameters

NOTICE

To ensure the normal operation of the battery system, after the energy storage system is powered on, the correct model needs to be selected through the SolarGo APP.

Step 1: Download the SoalrGo APP.

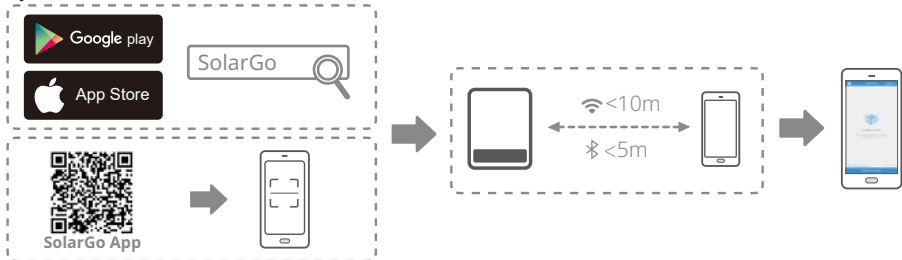

Step 2: Connect the inverter.

Step 3: Go to the parameter setting page through Home>Settings>Basic Settings, and follow the prompts to enter the battery model selection interface to set the battery model.

NOTICE

Incorrect selection of battery model may cause system failure. Please set the battery model correctly.

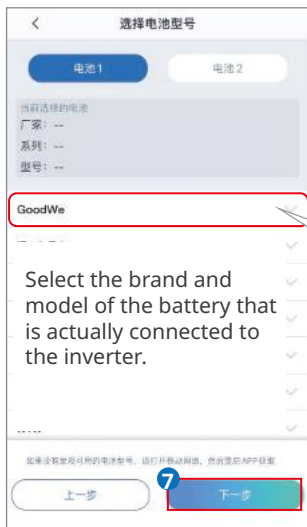

GW60KWH-D-10

Select the brand and model of the battery that is actually connected to the inverter.

8.3 Closing the cabinet door

Front door of battery system

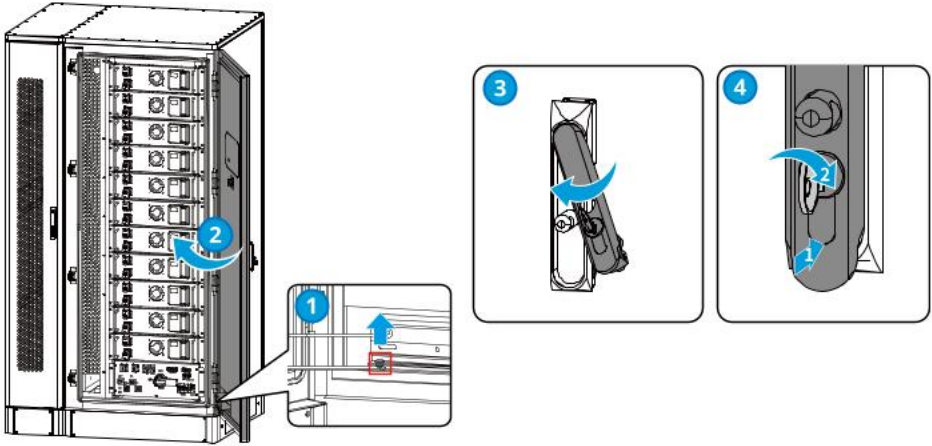

AC unit door and Battery system back door

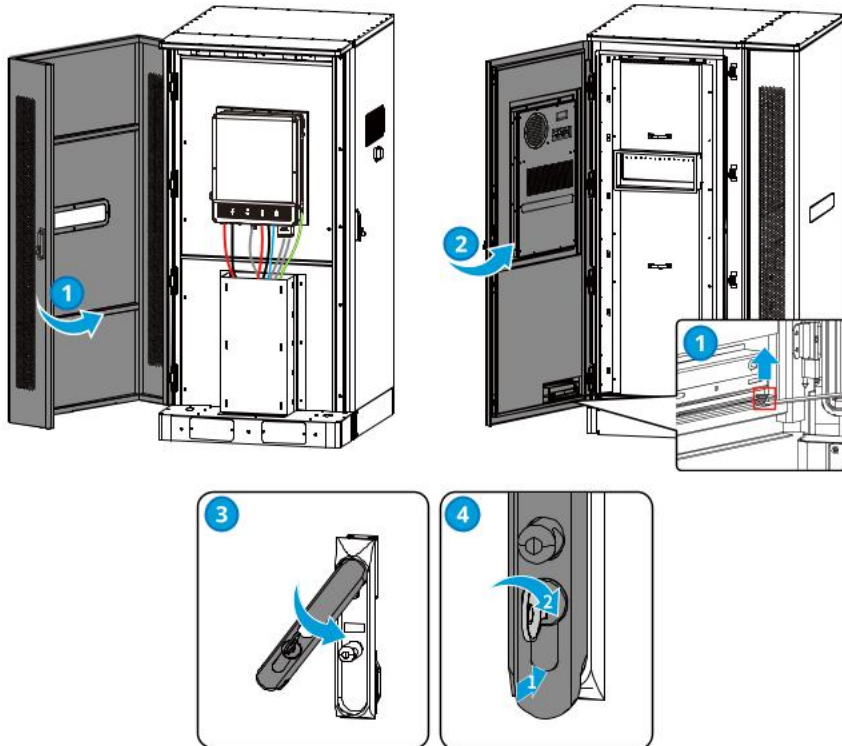

8.4 Pedestal installation

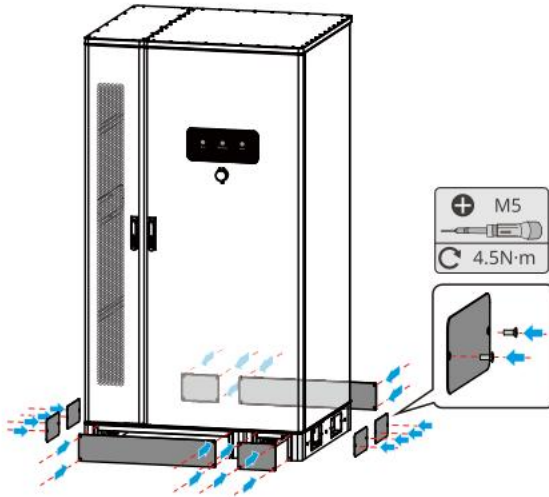

8.5 Air conditioning drainage pipe installation

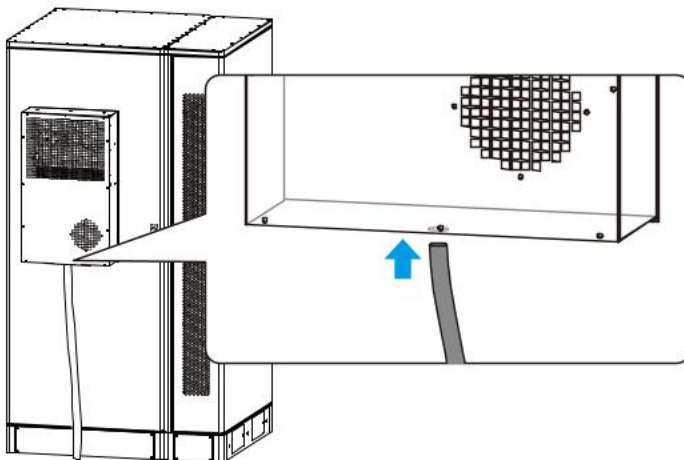

9 System maintenance

9.1 Power off the energy storage system



- Power off the inverter before operations and maintenance. Otherwise, the energy storage system may be damaged or electric shocks may occur.
- After the energy storage system is powered off, the internal components will take some time to discharge. Please wait for 10 minutes until the device is fully discharged.

9.2 Power off the equipment

Single Battery system

Step 1: Disconnect the AC switch.

Step 2: Disconnect the battery cluster switch

Step 3: Disconnect the DC power supply switch.

Step 4: Power off the inverter used in the system. Please refer to the corresponding inverter user manual for detailed operations.

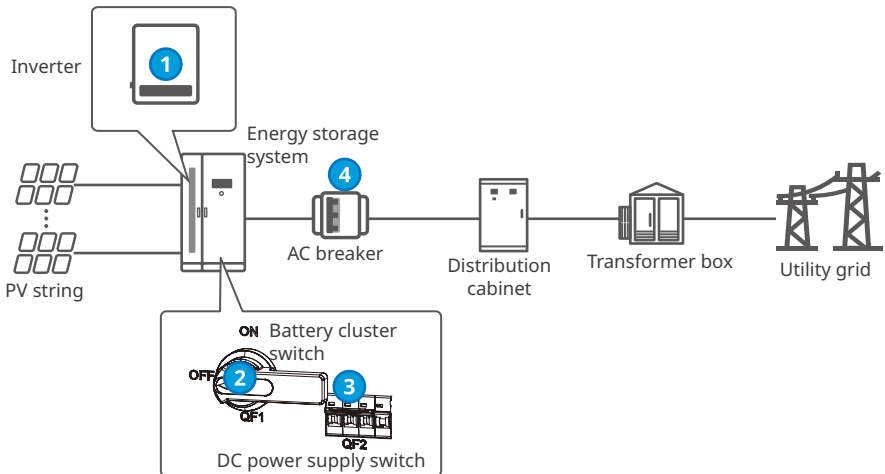

Power OFF

Power off: 4 → 2 → 3 → 1

Parallized battery systems

Step 1: Disconnect the AC switch.

Step 2: Disconnect the battery cluster switch of battery system 2, 3.

Step 3: Disconnect the battery cluster switch of battery system 1.

Step 4: Disconnect the DC power supply switch of all battery systems.

Step 5: Power off the inverter used in the system. Please refer to the corresponding inverter user manual for detailed operations.

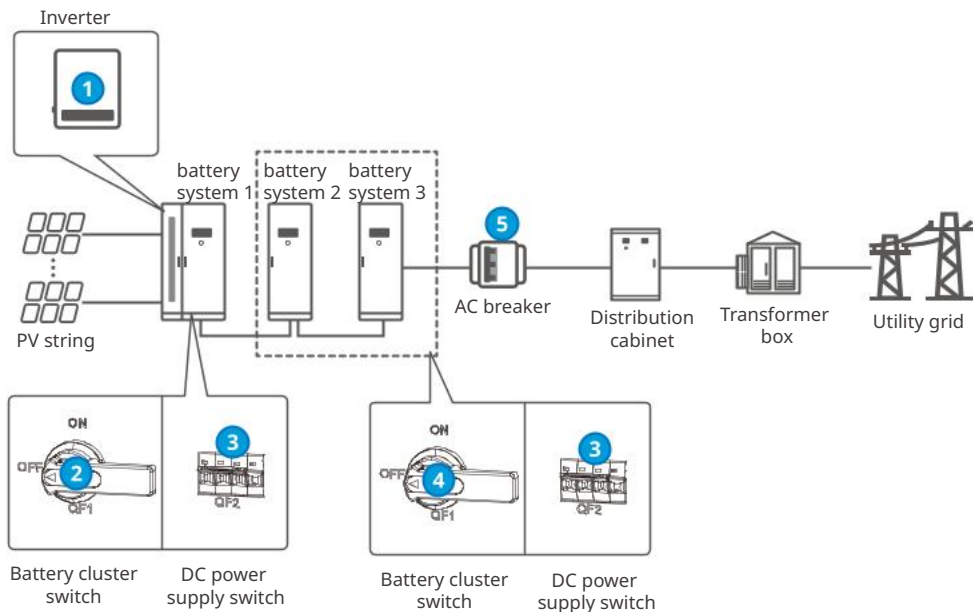

Power OFF

Power off:  →  →  →  → 

9.3 Removing the energy storage system

WARNING

- Ensure that the energy storage system is powered off.
- Wear proper PPE before any operations.

Step 1: Open the cabinet door.

Step 2: Disconnect all electrical connections of the energy storage system, including DC cables, AC cables, battery cables, communication cables, and protective grounding cables.

Step 3: Store the inverter properly. Ensure that the storage conditions meet the requirements for future use.

9.4 Disposing of the equipment

If the equipment cannot work anymore, dispose of it according to the local disposal requirements for electrical equipment waste. The equipment cannot be disposed of together with household waste.

9.5 Troubleshooting

Perform troubleshooting according to the following methods. Contact the after-sales service if these methods do not work.

Collect the information below before contacting the after-sales service, so that the problems can be solved quickly.

1. Equipment information like serial number, software version, installation date, fault time, fault frequency, etc.
2. Installation environment, including weather conditions, whether the PV modules are sheltered or shadowed, etc. It is recommended to provide some photos and videos to assist in analyzing the problem.
3. Utility grid situation.

No.	Fault	Cause	Solutions
1	Battery overvoltage protection	Continue charging when the battery is fully charged.	Stop charging, if the system is not automatically restored, contact professional technician to restart the system.
2	Battery undervoltage protection	Continue discharging when the battery is fully discharged.	Stop discharging, if the system is not automatically restored, contact professional technician to restart the system.
3	AC overcurrent protection	During the charging and discharging process, the current exceeds the maximum system current.	Reduce power, if the system is not automatically restored, contact professional technician to restart the system.
4	Battery over temperature protection	Excessive temperature during charging and discharging process.	Reduce battery temperature, if the system is not automatically restored, contact professional technician to restart the system.
5	Battery low-temperature protection	The temperature is too low during the charging and discharging process.	Increase battery temperature, if the system is not automatically restored, contact professional technician to restart the system.
6	Battery pole overtemperature protection	Excessive temperature during charging and discharging process.	Reduce battery temperature, if the system is not automatically restored, contact professional technician to restart the system.

7	Battery imbalance protection	Excessive temperature or pressure difference between individual cells.	Stop charging and discharging, and wait for the temperature difference to recover, and balance the pressure difference if it is too large.	
8	Insulation resistance protection	The insulation resistance of the system is low.	Check the grounding.	
9	Pre-charge failure	Pre-charge circuit components is damaged.	Check the pre-charging circuit components.	
10	Fault on data collecting cables	Abnormality on voltage, temperature, and current data collection cables.	Check the corresponding cable.	
11	Other faults	Relay open circuit	Relay fault	Replace relay.
		Relay short circuit	Relay fault	Replace relay.
		Parallel connection fault	Slave cluster lose connection.	Check the reliability of the master and slave cables.
		PCS communication loss	Abnormality on communication cable with PCS.	Check the reliability of cable connection.
		BMU communication failure	Abnormality on communication cable between BCU and BMU.	Check the reliability of cable connection.
		Air switch adhesion fault	Plastic shell air switch fault.	Replace the plastic shell air switch.
		Fault triggered by fire fighting system	Internal thermal runaway of the system	Contact the after-sales service.
12	Air conditioning fault	Fault occurs in the air conditioning system.	Contact the after-sales service.	

9.6 Routine Maintenance

 **DANGER**

- The cabinet contains strong electricity, and necessary safety precautions must be taken before starting maintenance.
- When performing maintenance, ensure that all switches are disconnected.
- The maintenance process must strictly follow the correct operating procedures.

 **WARNING**

- If any issues are found that may affect the battery or energy storage inverter system, please contact after-sales personnel and unauthorized disassembly is prohibited.
- If the copper wire inside the conductive wire is found to be exposed, do not touch it, and there is a danger of high voltage. Please contact after-sales personnel to prohibit unauthorized disassembly.
- If other unexpected situations occur, please contact after-sales personnel as soon as possible and operate under their guidance, or wait for on-site operation by after-sales personnel.

NOTICE

Moisture intrusion may cause damage to the energy storage system. To ensure the normal use of the energy storage system, avoid opening the cabinet door for maintenance or repair in rainy or humid weather conditions.

Maintaining Item	Maintaining Period
Check if any bolts are loose, and if so, tighten the corresponding positions.	Once 6 months
Check if the shell is damaged. If so, please touch up the paint or contact the after-sales service center.	Once 6 months
Check if the cable is aged or damaged. If so, please replace the corresponding cable or contact the after-sales service center.	Once 6 months
Check if there are any debris accumulation around the battery. If there are any, please clean them to avoid affecting the battery's heat dissipation.	Once 6 months
Check if there is accumulated water or pests to avoid long-term intrusion into the battery.	Once 6 months
Check if there are any abnormalities in the use of the door lock. If so, please replace it in a timely manner or contact the after-sales service center.	Once 6 months

10 Technical Parameters

Technical Data	GW60KWH-4H-A-10	GW60KWH-3H-A-10
Battery Data		
Usable Energy (kWh) ^{*2}	60	
Cell Type	LFP (LiFePO4)	
Pack Nominal Capacity (kWh)	5.76	
Number of Packs	11	
Nominal Voltage (V)	633.6	
Operating Voltage Range (V)	554.4-712.8	
Max. Charge/ Discharge Current (A) ^{*3}	96	
Max. Charge/ Discharge Rate	0.96C	
Cycle Life ^{*4}	≥5000	
Depth of Discharge	100%	
PV String Input Data		
Max. Input Power (kW) ^{*5}	22.5	30
Max. Input Voltage (V) ^{*6}	1000	1000
MPPT Operating Voltage Range (V)	200-850	200-850
MPPT Voltage Range at Nominal Power (V)	400-850	400-850
Start-up Voltage (V)	200	200
Nominal Input Voltage (V)	620	620
Max. Input Current per MPPT (A)	30	30
Max. Short Circuit Current per MPPT (A)	38	38
Max. Backfeed Current to The Array (A)	0	0
Number of MPP Trackers	2	2
Number of Strings per MPPT	2/2	2/2
AC Output Data (On-grid)		
Nominal Output Power (kW)	15	20
Max. Output Power (kW)	16.5	22
Nominal Apparent Power Output to Utility Grid (kVA)	15	20
Nominal Apparent Power from Utility Grid (kVA)	15	20
Max. Apparent Power Output to Utility Grid (kVA) ^{*7}	16.5	22
Max. Apparent Power from Utility Grid (kVA)	22.5	30

Technical Data	GW60KWH-4H-A-10	GW60KWH-3H-A-10
Nominal Output Voltage (V)	380/400, 3L/N/PE	380/400, 3L/N/PE
Output Voltage Range (V)* ⁸	0-300	0-300
Nominal AC Grid Frequency (Hz)	50/60	50/60
AC Grid Frequency Range (Hz)	45-65	45-65
Max. AC Current Output to Utility Grid (A)* ⁹	25.0	33.3
Max. AC Current from Utility Grid (A)	34.0	45.0
Max. Output Fault Current (Peak and Duration) (A)	241.5 (at 126ms)	241.5 (at 126ms)
Inrush Current (Peak and Duration) (A)	264 (at 53us)	264 (at 53us)
Nominal Output Current (A)* ¹⁰	22.7	30.3
Power Factor	~1 (Adjustable from 0.8 leading to 0.8 lagging)	~1 (Adjustable from 0.8 leading to 0.8 lagging)
Max. Total Harmonic Distortion	<3%	<3%
Maximum Output Overcurrent Protection (A)	94	94
AC Output Data (Back-up)		
Back-up Nominal Apparent Power (kVA)	15	20
Max. Output Apparent Power (kVA)* ¹¹	15(18 at 60sec , 24 at 3sec)	20(24 at 60sec , 32 at 3sec)
Nominal Output Current (A)	22.7	30.3
Max. Output Current (A)	22.7 (27.3 at 60sec, 36.4 at 3sec)	30.3 (36.4 at 60sec, 48.5 at 3sec)
Max. Output Fault Current (Peak and Duration) (A)	94	94
Inrush Current (Peak and Duration) (A)	264 (at 53us)	264 (at 53us)
Maximum Output Overcurrent Protection (A)	94	94
Nominal Output Voltage (V)	380/400	380/400
Nominal Output Frequency (Hz)	50/60	50/60
Output THDv (@Linear Load)	<3%	<3%
Efficiency		
Max. PCS Efficiency	98.00%	98.00%
European Efficiency	97.50%	97.50%
MPPT Efficiency	99.90%	99.90%
System Efficiency	89%	89%
Protection		

Technical Data	GW60KWH-4H-A-10	GW60KWH-3H-A-10
PV Reverse Polarity Protection	Integrated	
Battery Reverse Polarity Protection	Integrated	
Anti-islanding Protection	Integrated	
AC Overcurrent Protection	Integrated	
AC Short Circuit Protection	Integrated	
DC Surge Protection	Type II	
AC Surge Protection	Type III	
General Data		
Operating Temperature Range (°C)	Charge: 0 - +55; Discharge: -25 - +55	
Storage Temperature (°C)	0 - +35 (<One Year); -20 - 0 (≤One Month); +35 - +45 (≤One Month)	
Relative Humidity	0 - 95%	
Max. Operating Altitude (m)	3000	
Heating & Cooling	Air Conditioner	
User Interface	LED indicator, WLAN+APP	
Communication Interface	RS485, LAN	
Communication Protocol	Modbus-RTU; Modbus-TCP	
Weight (kg)	approx. 1053	
Dimension (W×H×D mm)	1108×2050× 1111.5	
Topology	Non-isolated	
Ingress Protection Rating	IP55	
Anti-Corrosion*12	C4 (Optional upgrade to C5)	
Fire Suppression	Perfluoro	
On/off-grid Switch Time	<10ms	
Certification*13		
Grid Standards	VDE-AR-N 4105, EN50549-1	
Safety Regulation	Inverter: IEC62619-1/-2 Battery: IEC62619/63056, IEC60730-1, IEC/EN62477-1, IEC62040-1	
EMC	Inverter: EN61000-6-1, EN61000-6-2, EN61000-6-3, EN61000-6-4 Battery: EN IEC61000-6-1, EN IEC61000-6-2, EN IEC61000-6-3, EN IEC61000-6-4	

Technical Data	GW60KWH-2H4-A-10	GW60KWH-2H-A-10 ^{*1}	GW60KWH-2H-A-10 ^{*1}
Battery Data			
Usable Energy (kWh) ^{*2}	60		
Cell Type	LFP (LiFePO4)		
Pack Nominal Capacity (kWh)	5.76		
Number of Packs	11		
Nominal Voltage (V)	633.6		
Operating Voltage Range (V)	554.4 - 712.8		
Max. Charge/ Discharge Current (A) ^{*3}	96		
Max. Charge/ Discharge Rate	0.96C		
Cycle Life ^{*4}	≥5000		
Depth of Discharge	100%		
PV String Input Data			
Max. Input Power (kW) ^{*5}	37.5	45	45
Max. Input Voltage (V) ^{*6}	1000	1000	1000
MPPT Operating Voltage Range (V)	200~850	200~850	200~850
MPPT Voltage Range at Nominal Power (V)	450~850	450~850	450~850
Start-up Voltage (V)	200	200	200
Nominal Input Voltage (V)	620	620	620
Max. Input Current per MPPT (A)	30	30	30
Max. Short Circuit Current per MPPT (A)	38	38	38
Max. Backfeed Current to The Array (A)	0	0	0
Number of MPP Trackers	3	3	3
Number of Strings per MPPT	2/2/2	2/2/2	2/2/2
AC Output Data (On-grid)			
Nominal Output Power (kW)	25	29.9	30
Max. Output Power (kW)	27.5	29.9	33
Nominal Apparent Power Output to Utility Grid (kVA)	25	29.9	30
Nominal Apparent Power from Utility Grid (kVA)	25	30	30

Technical Data	GW60KWH-2H4-A-10	GW60KWH-2H-A-10*1	GW60KWH-2H-A-10*1
Max. Apparent Power Output to Utility Grid (kVA)*7	27.5	29.9	33
Max. Apparent Power from Utility Grid (kVA)	33	33	33
Nominal Output Voltage (V)	380/400, 3L/N/PE	380/400, 3L/N/PE	380/400, 3L/N/PE
Output Voltage Range (V)*8	0~300	0~300	0~300
Nominal AC Grid Frequency (Hz)	50/60	50/60	50/60
AC Grid Frequency Range (Hz)	45~65	45~65	45~65
Max. AC Current Output to Utility Grid (A)*9	41.7	49.8	50.0
Max. AC Current from Utility Grid (A)	50.0	50.0	50.0
Max. Output Fault Current (Peak and Duration) (A)	241.5 (at 126ms)	241.5 (at 126ms)	241.5 (at 126ms)
Inrush Current (Peak and Duration) (A)	264 (at 53us)	264 (at 53us)	264 (at 53us)
Nominal Output Current (A)*10	37.9	45.3	45.5
Power Factor	~1 (Adjustable from 0.8 leading to 0.8 lagging)	~1 (Adjustable from 0.8 leading to 0.8 lagging)	~1 (Adjustable from 0.8 leading to 0.8 lagging)
Max. Total Harmonic Distortion	<3%	<3%	<3%
Maximum Output Overcurrent Protection (A)	94	94	94
AC Output Data (Back-up)			
Back-up Nominal Apparent Power (kVA)	25	29.9	30
Max. Output Apparent Power (kVA)*11	25 (30 at 60sec)	30 (36 at 60sec)	30 (36 at 60sec)
Nominal Output Current (A)	37.9	45.5	45.5
Max. Output Current (A)	37.9 (45.5 at 60sec)	45.5 (54.5 at 60sec)	45.5 (54.5 at 60sec)
Max. Output Fault Current (Peak and Duration) (A)	94	94	94

Technical Data	GW60KWH-2H4-A-10	GW60KWH-2H-A-10 ^{*1}	GW60KWH-2H-A-10 ^{*1}
Inrush Current (Peak and Duration) (A)	264 (at 53us)	264 (at 53us)	264 (at 53us)
Maximum Output Overcurrent Protection (A)	94	94	94
Nominal Output Voltage (V)	380/400	380/400	380/400
Nominal Output Frequency (Hz)	50/60	50/60	50/60
Output THDv (@Linear Load)	<3%	<3%	<3%
Efficiency			
Max. PCS Efficiency	98.00%	98.00%	98.00%
European Efficiency	97.50%	97.50%	97.50%
MPPT Efficiency	99.90%	99.90%	99.90%
System Efficiency	89%	89%	89%
Protection			
PV Reverse Polarity Protection	Integrated		
Battery Reverse Polarity Protection	Integrated		
Anti-islanding Protection	Integrated		
AC Overcurrent Protection	Integrated		
AC Short Circuit Protection	Integrated		
DC Surge Protection	Type II		
AC Surge Protection	Type III		
General Data			
Operating Temperature Range (°C)	Charge: 0 - +55; Discharge: -25 - +55		
Storage Temperature (°C)	0 - +35 (<One Year); -20 - 0 (≤One Month); +35 - +45 (≤One Month)		
Relative Humidity	0 - 95%		
Max. Operating Altitude (m)	3000		
Heating & Cooling	Air Conditioner		
User Interface	LED indicator, WLAN+APP		
Communication Interface	RS485, LAN		
Communication Protocol	Modbus-RTU; Modbus-TCP		
Weight (kg)	approx. 1053		
Dimension (W×H×D mm)	1108×2050× 1111.5		

Technical Data	GW60KWH-2H4-A-10	GW60KWH-2H-A-10 ^{*1}	GW60KWH-2H-A-10 ^{*1}
Topology	Non-isolated		
Ingress Protection Rating	IP55		
Anti-Corrosion ^{*12}	C4 (Optional upgrade to C5)		
Fire Suppression	Perfluoro		
On/off-grid Switch Time	<10ms		
Certification^{*13}			
Grid Standards	VDE-AR-N 4105, EN50549-1		
Safety Regulation	Inverter: IEC62619-1/-2 Battery: IEC62619/63056, IEC60730-1, IEC/EN62477-1, IEC62040-1		
EMC	Inverter: EN61000-6-1, EN61000-6-2, EN61000-6-3, EN61000-6-4 Battery: EN IEC61000-6-1, EN IEC61000-6-2, EN IEC61000-6-3, EN IEC61000-6-4		

Technical Data	GW60KWH-D-10
Battery Data	
Usable Energy (kWh) ^{*2}	60
Cell Type	LFP (LiFePO4)
Pack Nominal Capacity (kWh)	5.76
Number of Packs	11
Nominal Voltage (V)	633.6
Operating Voltage Range (V)	554.4~712.8
Max. Charge/ Discharge Current (A) ^{*3}	100
Max. Charge/ Discharge Rate	1C
Cycle Life ^{*4}	≥5000 Cycles
Depth of Discharge	100%
Efficiency	
System Efficiency	95%
General Data	
Operating Temperature Range (°C)	Charge: 0~+55; Discharge: -25~+55
Storage Temperature (°C)	0~+35(<One Year); -20~0(≤One Month) ; 35~40(≤One Month)
Relative Humidity	0~95%

Max. Operating Altitude (m)	3000
Heating & Cooling	Air Conditioner
User Interface	LED indicator
Communication Interface	CAN
Communication Protocol	CAN
Weight (kg)	approx. 900
Dimension (W×H×D mm)	808×2050× 1111.5
Ingress Protection Rating	IP55
Anti-Corrosion*12	C4 (Optional upgrade to C5)
Fire Suppresion	Perfluoro
Certification*13	
Safety Regulation	IEC62619/63056、IEC60730-1、IEC/EN62477-1 、IEC62040-1
EMC	EN IEC61000-6-1, EN IEC61000-6-2, EN IEC61000-6-3, EN IEC61000-6-4

*1: The choice of inverter type (ET 29.9 or ET 30) depending on local grid policy. Actual inverter type (ET 29.9 or ET 30) will subject to purchase order.

*2: Test conditions, 100% DOD, 0.5C charge & discharge at +25±2 °C for battery system at beginning life. System Usable Energy may vary with different Inverter.

*3: Actual Dis-/Charge Current and power derating will occur related to Temperature and SOC.

*4: Based on Cell test condition of 25±2°C, 0.5C/0.5C and 80% EOL.

*5: Max. Input Power, not continuous for 1.5*normal power.

*6: For 1000V system, Maximum operating voltage is 950V.

*7: According to the local grid regulation.

*8: Output Voltage Range: phase voltage.

*9: For 400V grid (such as Australia, Germany, etc.), the Max. AC Current Output to Utility Grid is 23.9A for GW15K-ET, 31.9A for GW20K-ET, 39.9A for GW25K-ET, 43.3A for GW29.9K-ET, 47.8A for GW30K-ET.

*10: For 400V grid (such as Australia, Germany, etc.), the Nominal Output Current is 21.7A for GW15K-ET, 29.0A for GW20K-ET, 36.2A for GW25K-ET, 43.3A GW29.9K-ET, 43.5A for GW30K-ET.

*11: Can be reached only if PV and battery power is enough.

*12: Excluding locks.

*13: Not all certifications & standards listed, check the official website for detail.



Official Website

GoodWe Technologies Co., Ltd.

 No. 90 Zijin Rd., New District, Suzhou, 215011, China

 www.goodwe.com

 service@goodwe.com



Contact Information